

MUSKOX

PARTS MANUAL

MODELS 25-60, 25-78 & 25-90



601 FIRST STREET NORTH | MENTOR, MN 56736
PH: 218.288.1905 | WEB: WWW.MUSKOXMN.COM

TABLE OF CONTENTS

PREFACE	5	LOADER HOSES	
AUGER CHAIN & CHAIN TENSIONER	6	STANDARD	24
AUGER MOTOR	7	BOBCAT	25
BACKDRAG POLES	8	SINGLE ARM / RIGHT SIDE	26
CHUTE ASSEMBLY & CHUTE MOTOR	9	IMPELLER	27
CUTTING EDGES		LEVELING WHEEL	28
25-60	10	LOWER AUGER	
25-78	11	25-60	29
25-90	12	25-78	30
DECAL GRAPHICS KIT	13	25-90	31
ELECTRONICS	14	MOUNTING PLATE	32
WIRING HARNESS SETUP	15	PLASTICS - GLIDE PLATE	33
HYDRAULICS - CONTROL BLOCK ASSY		PLASTIC WEAR KITS	
25-60	16	25-60	34
25-78	17	25-78	35
25-90	18	25-90	36
HYDRAULICS		SIDE FINS	37
AUGER HOSES	19	UPPER AUGER	
CHUTE DEFLECTION HOSES	20	25-60	38
CHUTE ROTATE HOSES	21	25-78	39
IMPELLER MOTOR HOSES	22	25-90	40
IMPELLER MOTOR	23	BOLT TORQUE SPECIFICATIONS	41



PREFACE

INTRODUCTION

For your safety and continued proper operation, use only genuine Muskox service parts. When ordering service parts, specify the correct part number, full description, quantity required, and the unit model number and serial number.

The model and serial number plate is located left of the chute on the fan housing (see below).

Muskox reserves the right to make changes or improvements in the design or construction of any part of the unit without incurring the obligation to install such changes on any previously delivered units.

NOTE: The illustrations and data used in this manual were current (according to the information available to us) at the time of printing, however, we reserve the right to redesign and change the attachment as may be necessary without notification.

Standard attaching hardware torque values are provided on the last page of this manual.

Items shown in the parts list that do not have part numbers are shown for reference purposes only and are NOT available for purchase.

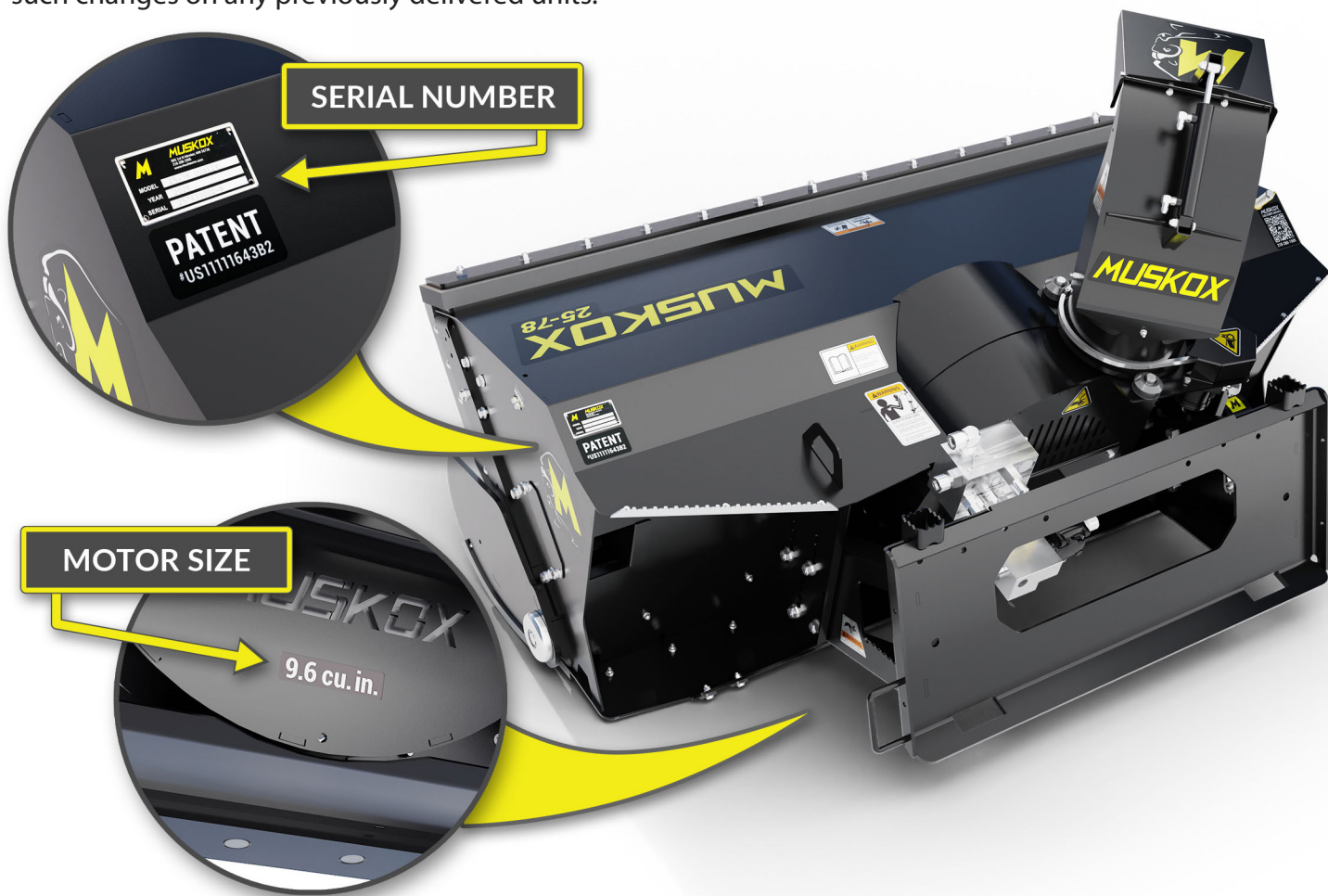

For the most updated information on MUSKOX products and services, please visit www.muskoxmn.com/support. There you will find service and maintenance videos, tips, advice and more.

AUGER CHAIN & CHAIN TENSIONER

FOR ALL MODELS

MODEL 25-60 ▼

MODEL 25-78 ▼

MODEL 25-90 ▼

CHAIN TENSIONER-KIT

700-0131-R1

INCLUDES

- NUT,FLG NYL-1/2"-Z&C
QUANTITY: 1
- BOLT,HEX-1/2"x2 1/4"-GR5 Z&C
QUANTITY: 1
- SPROCKET,15T 1/2" BORE 60P-IDLER W/BALL BEARING
QUANTITY: 1
- SPACER,PULLEY-TENSION IDLER-Z&C
QUANTITY: 2
- SPRING TENSIONER, TUBE
QUANTITY: 1
- TENSIONER SPRING
QUANTITY: 1
- SPRING TENSIONER GUIDE, TUBE
QUANTITY: 1
- TAP BOLT, HEX 1/2"x8"-GR5 Z&C
QUANTITY: 1
- TENSIONER, THREADED-SPOOL
QUANTITY: 1
- NUT,FLG NYL-3/8"-Z&C
QUANTITY: 2
- BOLT,HEX-3/8"x1"-GR5 Z&C
QUANTITY: 2
- WASHER,FLAT,SAE-3/8"-Z&C
QUANTITY: 2
- PRONG, COTTER PIN-5/32"x1 1/2" - Z&C
QUANTITY: 2

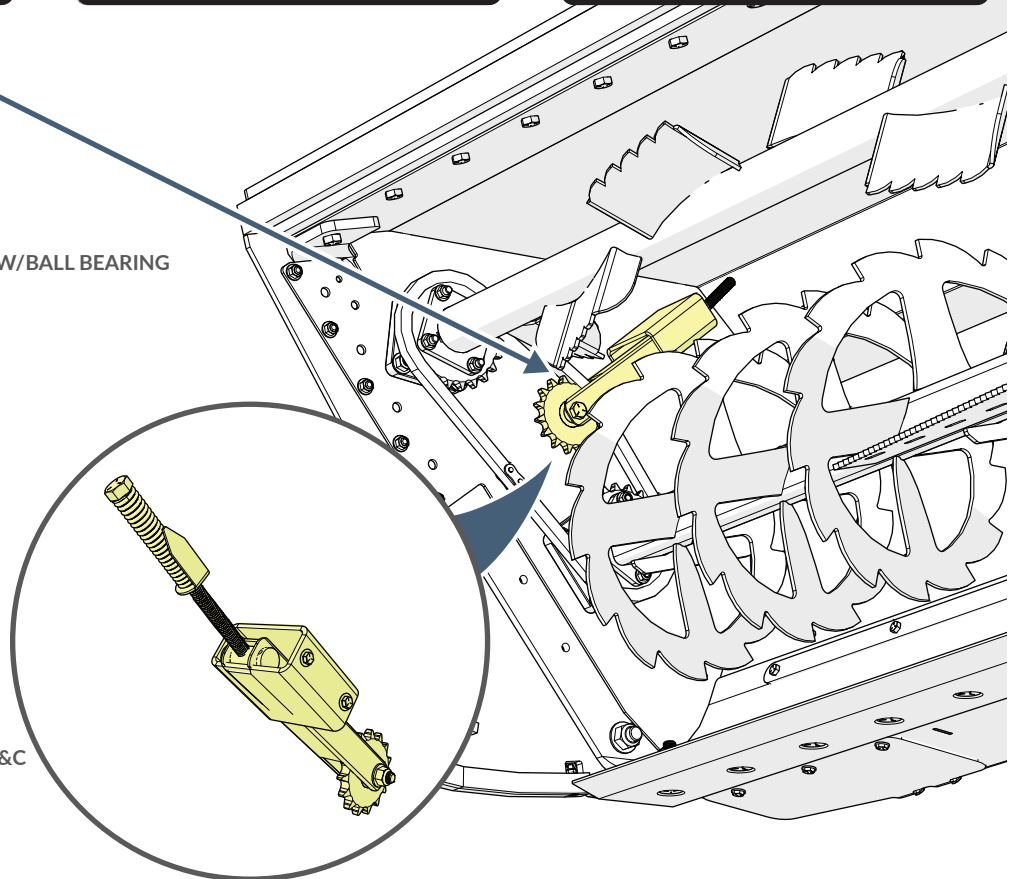

INDIVIDUAL PARTS AVAILABLE

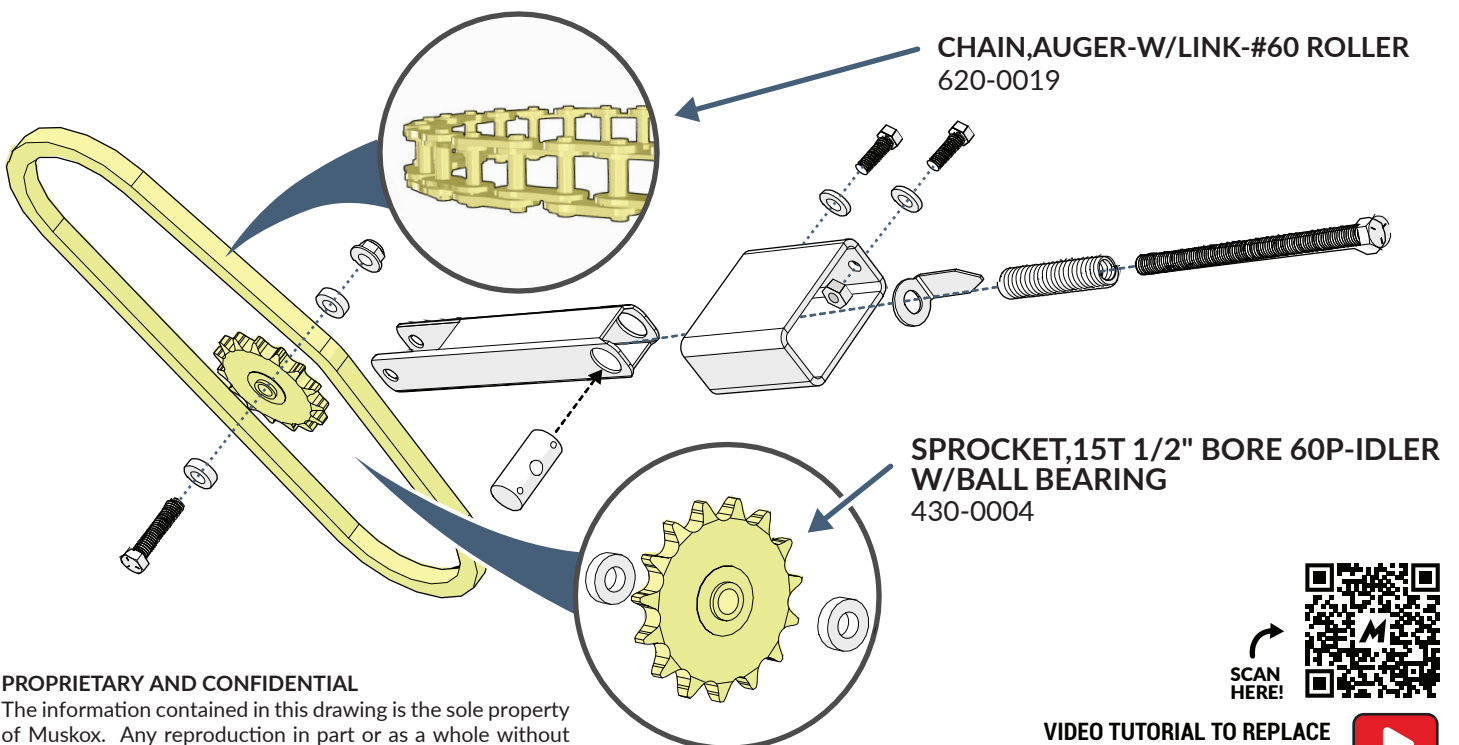

PROPRIETARY AND CONFIDENTIAL

The information contained in this drawing is the sole property of Muskox. Any reproduction in part or as a whole without the written permission of Muskox is prohibited.



VIDEO TUTORIAL TO REPLACE
AUGER CHAIN & CHAIN TENSIONER



AUGER MOTOR

FOR ALL MODELS

MODEL 25-60 ▼

MODEL 25-78 ▼

MODEL 25-90 ▼

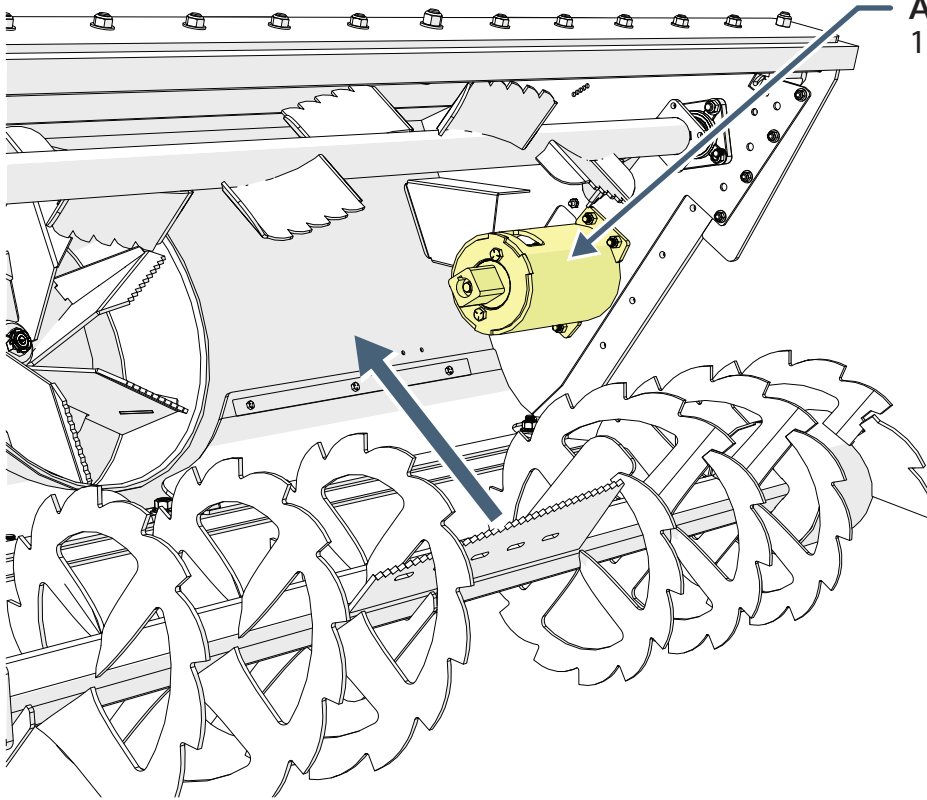

AUGER MOTOR-ASSY

1809-025 QUANTITY: 1

INCLUDES

- MOTOR,24.0 CIR-AUGER
QUANTITY: 1
- WASHER,LOCK-3/8"-Z&C
QUANTITY: 1
- BOLT,HEX-3/8"X1"-GR8 Z&Y
QUANTITY: 1
- ADAPTER,HYD MOTOR TO LWR AUGER-WELDT
QUANTITY: 1
- HOUSING,AUGER MOTOR-WELDT
QUANTITY: 1
- FITTING, 12MJ-10MORB STRAIGHT
QUANTITY: 2
- BOLT,HEX-1/2"X1 3/4"-GR8 Z&Y
QUANTITY: 2
- NUT,HEX TOPLOCK-1/2"-ECO-GR9
QUANTITY: 2
- AUGER MOTOR INSTALL FASTENERS
701-0021 QUANTITY: 1

INCLUDES

- BOLT,HEX-1/2"X1 1/2"-GR5 Z&C
QUANTITY: 4
- NUT,HEX NYL-1/2"-Z&C
QUANTITY: 4
- WASHER,FLAT,SAE-1/2"-Z&C
QUANTITY: 4

INDIVIDUAL PARTS AVAILABLE

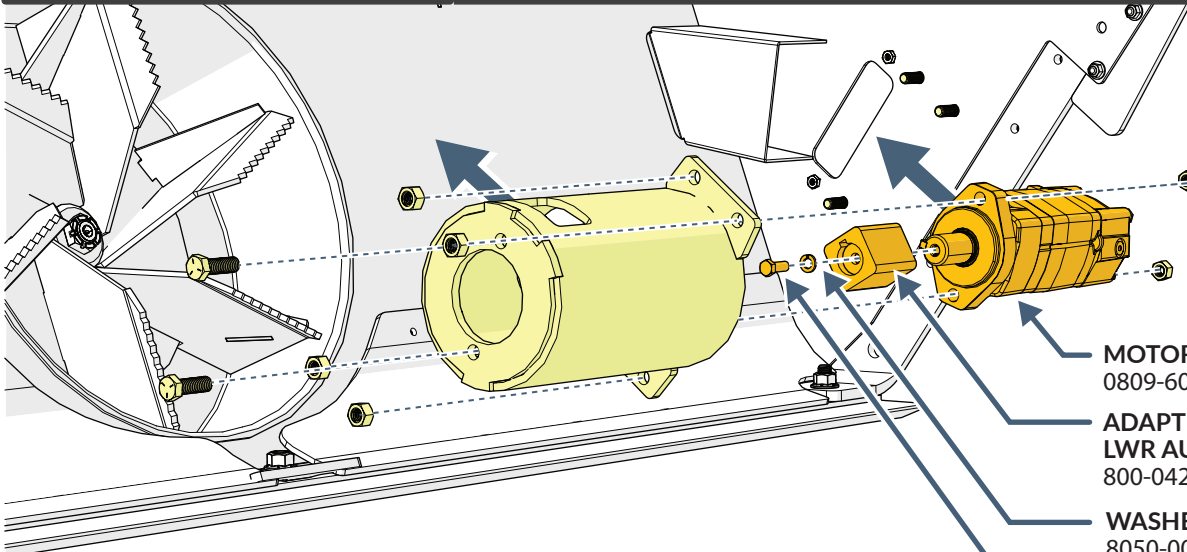

MOTOR,24.0 CIR-AUGER
0809-603 QUANTITY: 1

ADAPTER,HYD MOTOR TO
LWR AUGER-WELDT
800-0429 QUANTITY: 1

WASHER,LOCK-3/8"-Z&C
8050-002 QUANTITY: 1

BOLT,HEX-3/8"X1"-GR8 Z&Y
8002-203 QUANTITY: 1



SCAN
HERE!



VIDEO TUTORIAL TO REPLACE
BOTTOM AUGER AND AUGER BEARINGS

PROPRIETARY AND CONFIDENTIAL

The information contained in this drawing is the sole property of MuskoX. Any reproduction in part or as a whole without the written permission of MuskoX is prohibited.

BACKDRAG POLES

FOR ALL MODELS

MODEL 25-60 ▼

MODEL 25-78 ▼

MODEL 25-90 ▼

PROPRIETARY AND CONFIDENTIAL
The information contained in this drawing is the sole property of MuskoX. Any reproduction in part or as a whole without the written permission of MuskoX is prohibited.

BACKDRAG POLE SET 700-1505

INCLUDES

- FIBERGLASS, GUIDE POLE-1/4"X48"
QUANTITY: 2
- NUT, FLG NYL-1/4"-Z&C
QUANTITY: 4
- POINTER, GUIDE POLE
QUANTITY: 2
- U-BOLT, 1/4"-POLE
QUANTITY: 2

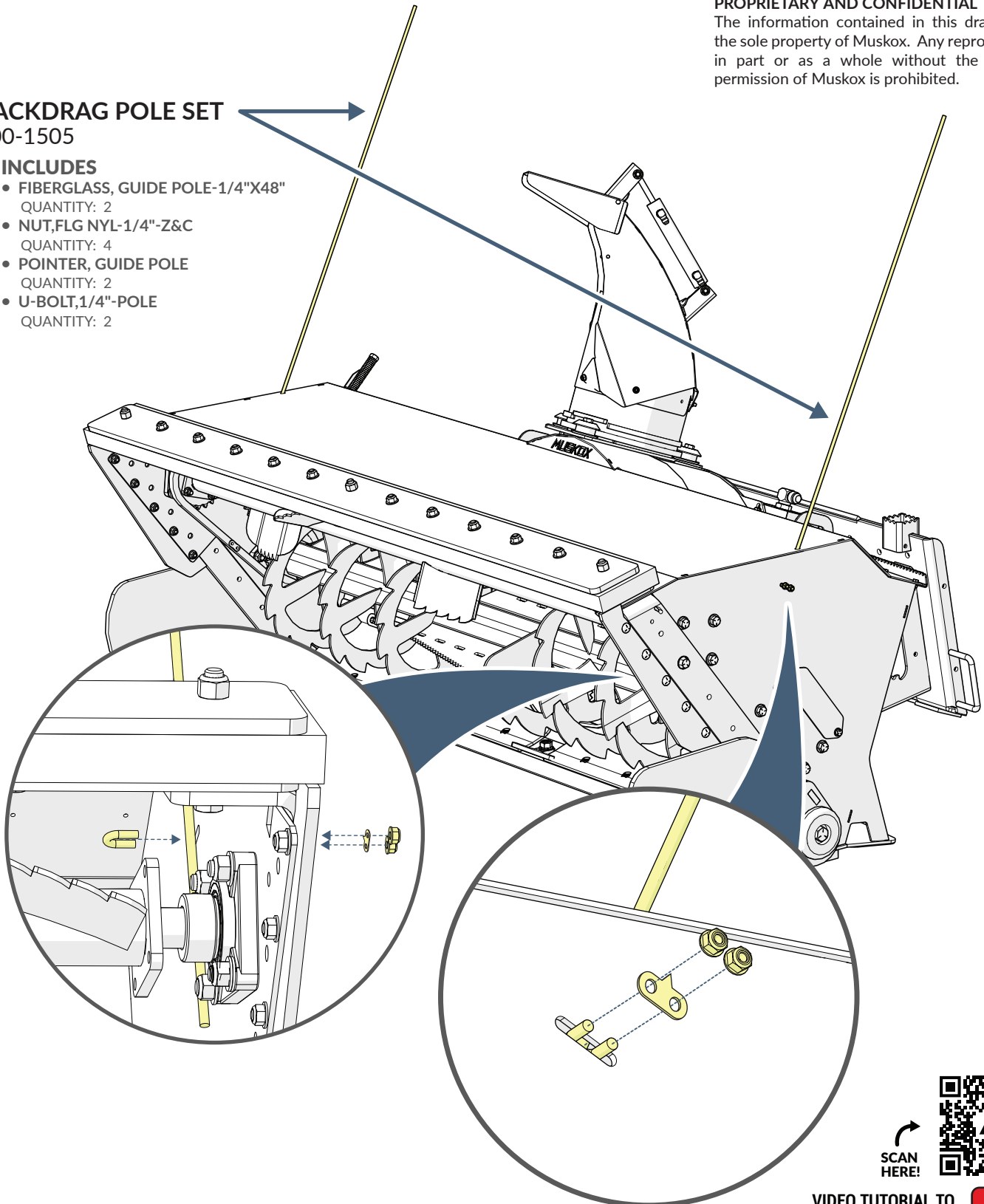

SCAN
HERE!



VIDEO TUTORIAL TO
REPLACE BACKDRAG POLES



CHUTE ASSEMBLY & CHUTE MOTOR

FOR ALL MODELS

MODEL 25-60 ▼

MODEL 25-78 ▼

MODEL 25-90 ▼

PROPRIETARY AND CONFIDENTIAL

The information contained in this drawing is the sole property of Muskox. Any reproduction in part or as a whole without the written permission of Musk

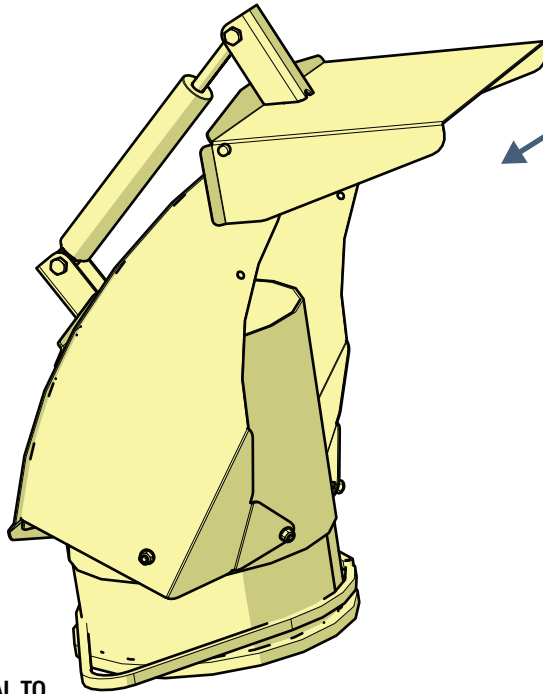

CHUTE, ASSY
700-0105

INCLUDES

- NUT,FLG NYL-3/8"-Z&C
QUANTITY: 2
- FITTING,6MJ-4MORB-90 DEG
QUANTITY: 2
- CYLINDER,10 1/2" 4"STK 1 3/4"-CHUTE
QUANTITY: 1
- CHUTE-WELDT
QUANTITY: 1
- CHUTE,ROTATION-WELDT
QUANTITY: 1
- BOLT,HEX-1/4"X3/4"-GR5 Z&C
QUANTITY: 7
- BOLT,HEX-3/8"X1 3/4"-GR5 Z&C
QUANTITY: 2
- SCREW,MACH,PAN HD 1/4"X1/2"-PHILLIPS
QUANTITY: 2
- NUT,FLG NYL-1/4"-Z&C
QUANTITY: 9
- GUARD,CHUTE-HMW-BLACK
QUANTITY: 1
- SHROUD,CHUTE-HMW-BLACK
QUANTITY: 1
- CHAIN,CHUTE-W/LINKS-#40 STAINLESS ROLLER
QUANTITY: 1



SCAN HERE!



VIDEO TUTORIAL TO REPLACE CHUTE CHAIN

INDIVIDUAL PARTS AVAILABLE

CYLINDER,10 1/2" 4"STK 1 3/4"-CHUTE
0809-609

GUARD,CHUTE-HMW-BLACK
611-0005

SHROUD,CHUTE-HMW-BLACK
611-0007

CHAIN,CHUTE-W/LINKS-#40 STAINLESS ROLLER
620-0024

CHUTE,ROLLER-ASSY
700-0100

INCLUDES

- BOLT,HEX-1/2"X2 1/2"-GR5 Z&C
QUANTITY: 1
- NUT,FLG NYL-1/2"-Z&C
QUANTITY: 1
- ROLLER,CHUTE ROTATION-TAPERED
QUANTITY: 1
- BUSHING,CHUTE ROLLER
QUANTITY: 1
- WASHER,FLAT,USS-1/2"-Z&C
QUANTITY: 2

SPROCKET,15T 1" BORE 40P
430-0003

CHUTE MOTOR-ASSY
700-0141

INCLUDES

- MOTOR,2.8 CIR-CHUTE
QUANTITY: 1
- FITTING,6MJ-10MORB-90 DEG
QUANTITY: 2
- SPROCKET,15T 1" BORE 40P
QUANTITY: 1



SCAN HERE!

VIDEO TUTORIAL TO REPLACE UHMW CHUTE LINER



CUTTING EDGES

FOR MODEL

MODEL 25-60 ▼

MODEL 25-78 ▼

MODEL 25-90 ▼

PROPRIETARY AND CONFIDENTIAL

The information contained in this drawing is the sole property of Muskox. Any reproduction in part or as a whole without the written permission of Muskox is prohibited.

CUTTING EDGE ,TOP, 1/2" THK-60"BLWR

610-1610
QUANTITY: 2

BUSHING,RUBBER CUT EDGE

620-0057
QUANTITY 2

SCRAPING EDGE, RUBBER-60"

611-0019
QUANTITY 1

60" - UPPER CUTTING EDGE INSTALL FASTENERS 701-0002

INCLUDES

- TAP BOLT,HEX-1/2"X3 1/2"-GR5 Z&C
QUANTITY: 8
- BOLT,HEX-9/16"X4"-GR5 Z&C
QUANTITY: 2
- WASHER,FLAT,SAE-9/16"-Z&C
QUANTITY: 2
- NUT,FLG NYL-1/2"-Z&C
QUANTITY: 8
- NUT,HEX NYL-9/16"-Z&C
QUANTITY: 2
- NUT,HEX-1/2"-GR5 Z&C
QUANTITY: 8

NOTE:
CUTTING EDGE ,TOP
brackets are installed
in oposite directions.

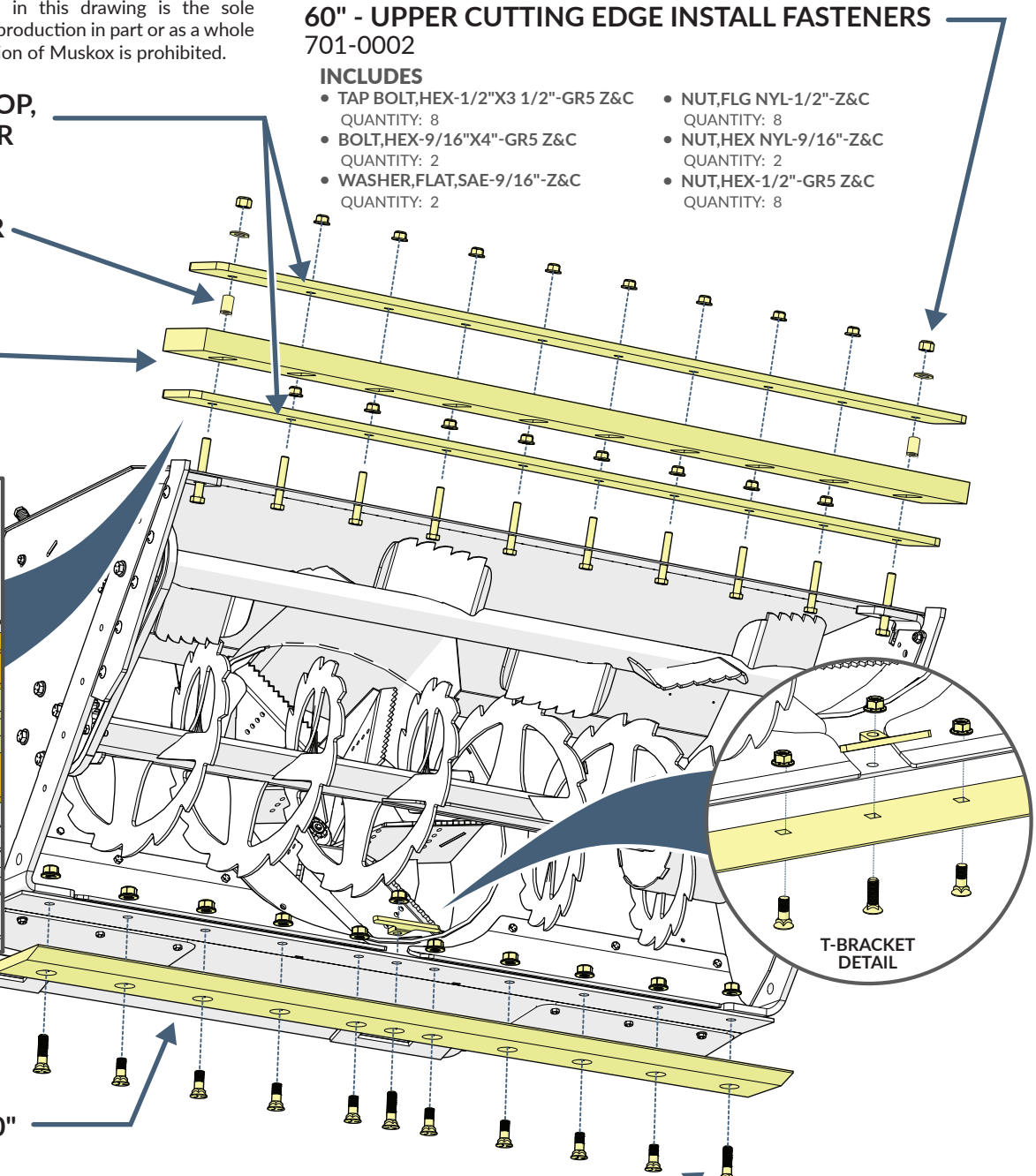
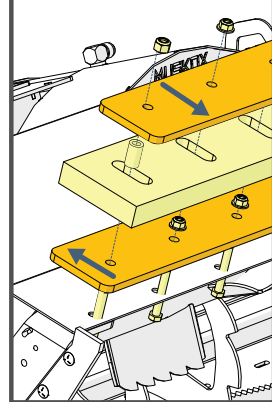

EDGE,CUTTING-60"

620-0069
QUANTITY 1

60" - LOWER CUTTING EDGE INSTALL FASTENERS 701-0001

INCLUDES

- BOLT,PLOW-5/8"X1 1/2"-GR8 PLAIN
QUANTITY: 8
- BOLT,PLOW-5/8"X2 1/4"-GR8 PLAIN
QUANTITY: 2
- NUT,HEAVY HEX-5/8"-PLAIN
QUANTITY: 10

T-BRACKET INSTALL FASTENERS

- T BRKT-HMW HOLD DOWN
QUANTITY: 1
- BOLT,PLOW-5/8"X2"-GR8 PLAIN
QUANTITY: 1
- NUT,HEAVY HEX-5/8"-PLAIN
QUANTITY: 1



SCAN
HERE!



VIDEO TUTORIAL TO
REPLACE RUBBER CUT EDGE



SCAN
HERE!



VIDEO TUTORIAL TO REPLACE
LOWER STEEL CUT EDGE

CUTTING EDGES

MODEL 25-60 ▼

FOR MODEL
MODEL 25-78 ▼

MODEL 25-90 ▼

PROPRIETARY AND CONFIDENTIAL

The information contained in this drawing is the sole property of MuskoX. Any reproduction in part or as a whole without the written permission of MuskoX is prohibited.

**CUTTING EDGE ,TOP,
1/2" THK-78"BLWR**
610-1618
QUANTITY: 2

**BUSHING,RUBBER
CUT EDGE**
620-0057
QUANTITY 3

**SCRAPING EDGE,
RUBBER-78"**
611-0006
QUANTITY 1

78" - UPPER CUTTING EDGE INSTALL FASTENERS 701-0017

INCLUDES

- TAP BOLT,HEX-1/2"X3 1/2"-GR5 Z&C QUANTITY: 10
- BOLT,HEX-9/16"X4"-GR5 Z&C QUANTITY: 2
- BOLT,HEX-9/16"X3 1/2"-GR5 Z&C QUANTITY: 1
- WASHER,FLAT,SAE-9/16"-Z&C QUANTITY: 3
- NUT,FLG NYL-1/2"-Z&C QUANTITY: 10
- NUT,HEX NYL-9/16"-Z&C QUANTITY: 3
- NUT,HEX-1/2"-GR5 Z&C QUANTITY: 10

NOTE:
CUTTING EDGE ,TOP
brackets are installed
in opposite directions.

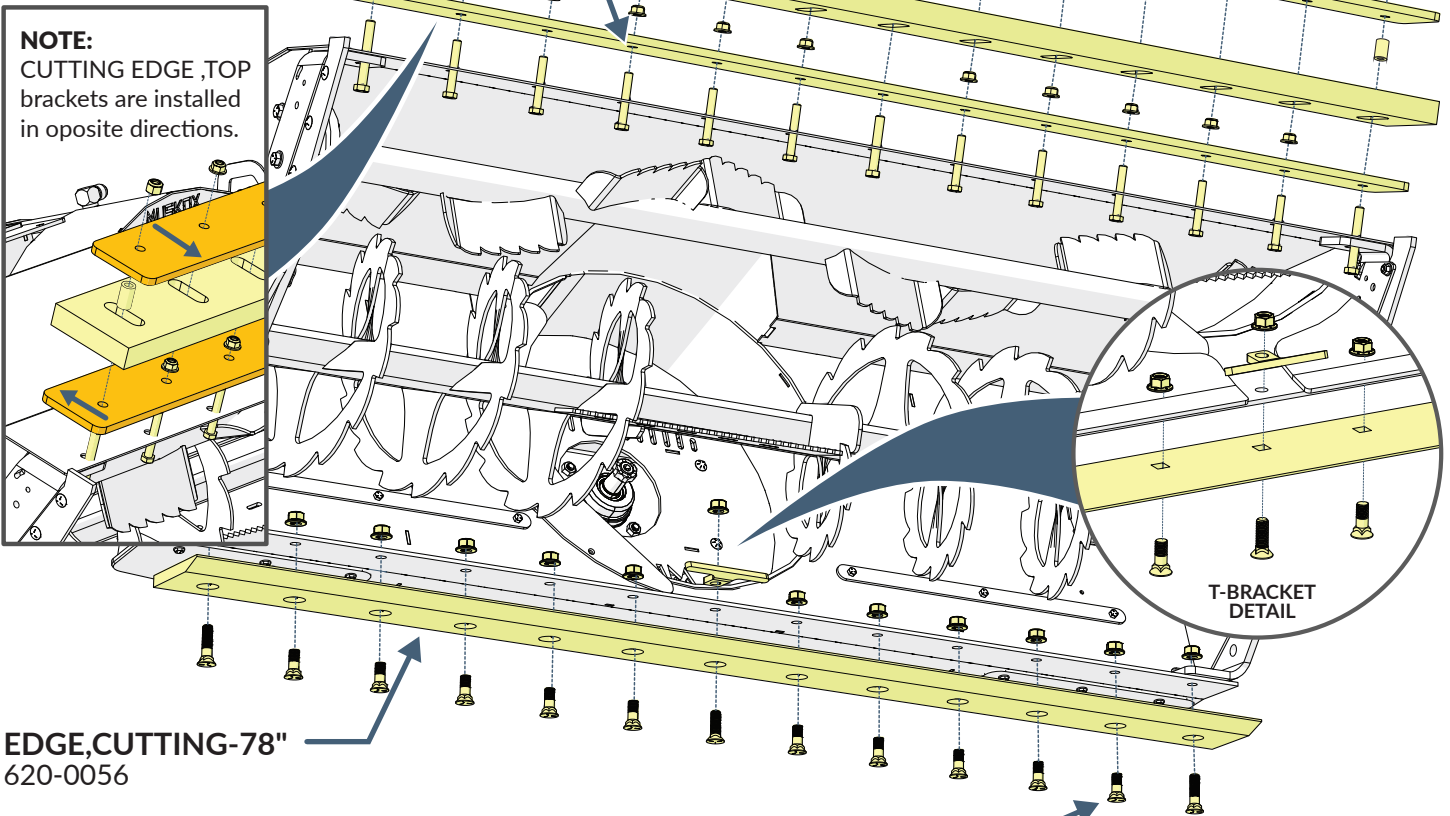

EDGE,CUTTING-78"
620-0056

78" - LOWER CUTTING EDGE INSTALL FASTENERS 701-0016

INCLUDES

- BOLT,PLOW-5/8"X1 1/2"-GR8 PLAIN QUANTITY: 10
- BOLT,PLOW-5/8"X2 1/4"-GR8 PLAIN QUANTITY: 2
- NUT,HEAVY HEX-5/8"-PLAIN QUANTITY: 12

T-BRACKET INSTALL FASTENERS

- T BRKT-HMW HOLD DOWN QUANTITY: 1
- BOLT,PLOW-5/8"X2"-GR8 PLAIN QUANTITY: 1
- NUT,HEAVY HEX-5/8"-PLAIN QUANTITY: 1



SCAN
HERE!



**VIDEO TUTORIAL TO
REPLACE RUBBER CUT EDGE**



SCAN
HERE!



**VIDEO TUTORIAL TO REPLACE
LOWER STEEL CUT EDGE**

CUTTING EDGES

MODEL 25-60 ▼

MODEL 25-78 ▼

FOR MODEL
MODEL 25-90 ▼

PROPRIETARY AND CONFIDENTIAL

The information contained in this drawing is the sole property of Muskox. Any reproduction in part or as a whole without the written permission of Muskox is prohibited.

**CUTTING EDGE ,TOP,
1/2" THK-90"BLWR**
610-1619
QUANTITY: 2

**BUSHING,RUBBER
CUT EDGE**
620-0057
QUANTITY 4

**SCRAPING EDGE,
RUBBER-90"**
611-0012
QUANTITY 1

90" - UPPER CUTTING EDGE INSTALL FASTENERS
701-0020

INCLUDES

- TAP BOLT,HEX-1/2"X3 1/2"-GR5 Z&C QUANTITY: 11
- BOLT,HEX-9/16"X4"-GR5 Z&C QUANTITY: 2
- BOLT,HEX-9/16"X3 1/2"-GR5 Z&C QUANTITY: 2
- WASHER,FLAT,SAE-9/16"-Z&C QUANTITY: 4
- NUT,FLG NYL-1/2"-Z&C QUANTITY: 11
- NUT,HEX NYL-9/16"-Z&C QUANTITY: 4
- NUT,HEX-1/2"-GR5 Z&C QUANTITY: 11

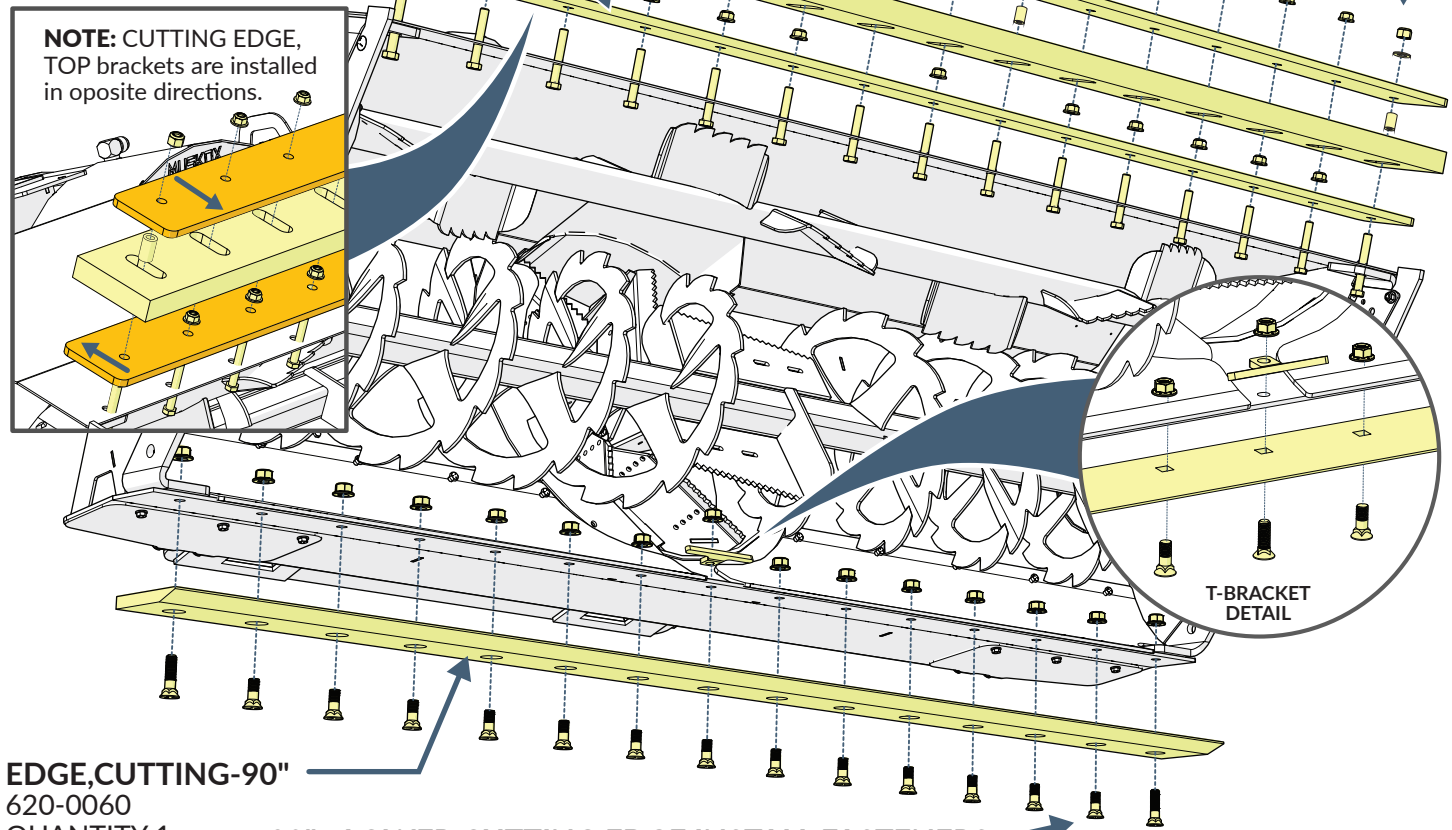

EDGE,CUTTING-90"
620-0060
QUANTITY 1

90" - LOWER CUTTING EDGE INSTALL FASTENERS
701-0019

INCLUDES

- BOLT,PLOW-5/8"X1 1/2"-GR8 PLAIN QUANTITY: 12
- BOLT,PLOW-5/8"X2 1/4"-GR8 PLAIN QUANTITY: 2
- NUT,HEAVY HEX-5/8"-PLAIN QUANTITY: 14

T-BRACKET INSTALL FASTENERS

- T BRKT-HMW HOLD DOWN QUANTITY: 1
- BOLT,PLOW-5/8"X2"-GR8 PLAIN QUANTITY: 1
- NUT,HEAVY HEX-5/8"-PLAIN QUANTITY: 1



SCAN HERE!

**VIDEO TUTORIAL TO
REPLACE RUBBER CUT EDGE**



SCAN HERE!

**VIDEO TUTORIAL TO REPLACE
LOWER STEEL CUT EDGE**

DECAL GRAPHICS KIT

FOR ALL MODELS

MODEL 25-60 ▼

MODEL 25-78 ▼

MODEL 25-90 ▼

PROPRIETARY AND CONFIDENTIAL

The information contained in this drawing is the sole property of MuskoX. Any reproduction in part or as a whole without the written permission of MuskoX is prohibited.

25-60 MODELS

KIT,GRAPHIC PACKAGE-2560/BLACK
0309-2560B QUANTITY: 1



KIT,GRAPHIC PACKAGE-2560/POALR
0309-2560W QUANTITY: 1



25-78 MODELS

KIT,GRAPHIC PACKAGE-2578/BLACK
0309-2578B QUANTITY: 1



KIT,GRAPHIC PACKAGE-2578/POLAR
0309-2578W QUANTITY: 1

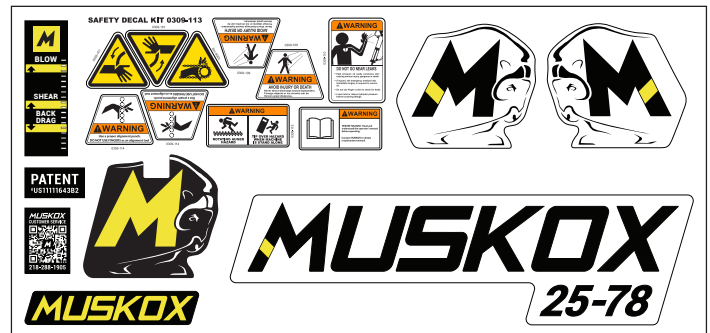

25-90 MODELS

KIT,GRAPHIC PACKAGE-2590/BLACK
0309-2590B QUANTITY: 1



KIT,GRAPHIC PACKAGE-2590/POLAR
0309-2590W QUANTITY: 1



ELECTRONICS

FOR ALL MODELS

MODEL 25-60 ▼

MODEL 25-78 ▼

MODEL 25-90 ▼

PROPRIETARY AND CONFIDENTIAL

The information contained in this drawing is the sole property of MuskoX. Any reproduction in part or as a whole without the written permission of MuskoX is prohibited.

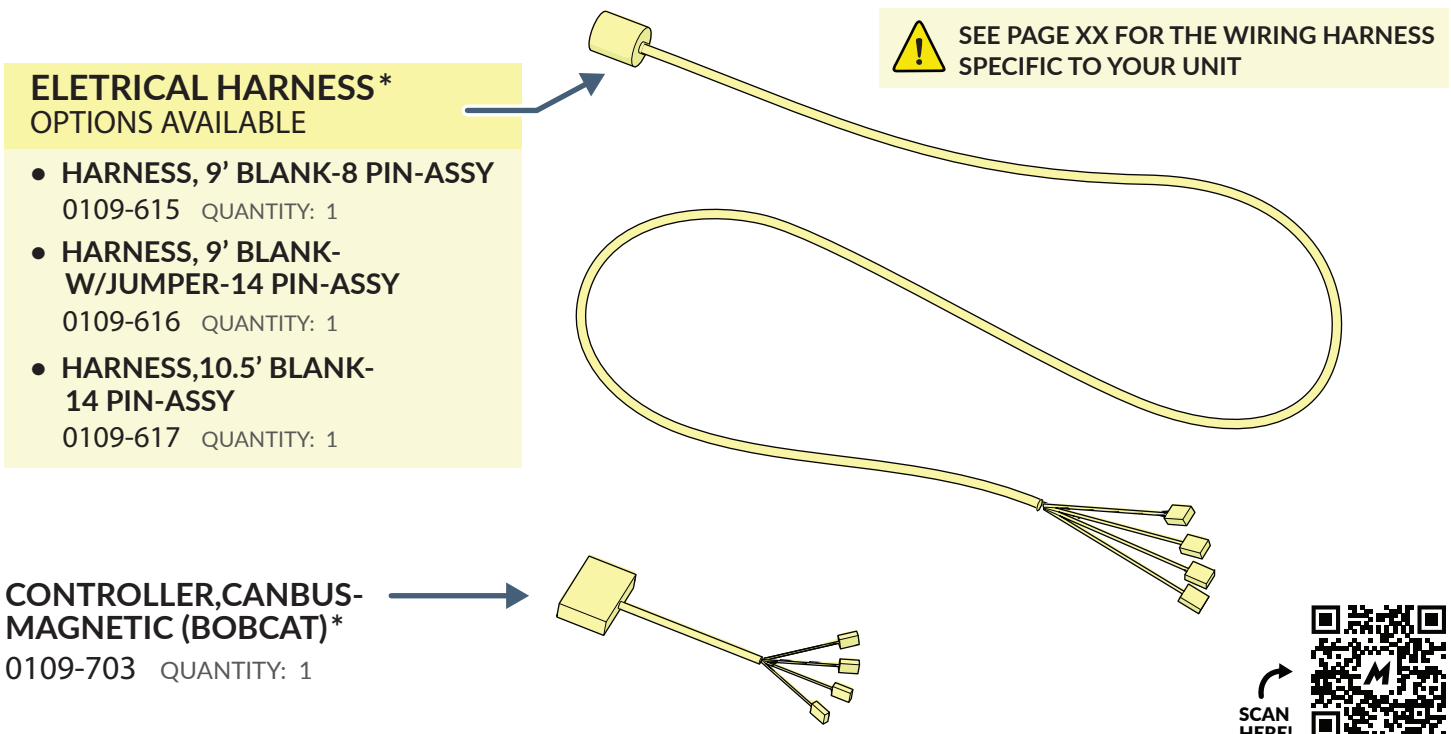

⚠ * CONTACT MUSKOX FOR PINOUT AND CONFIGURATION SPECIFIC TO YOUR UNIT

VIDEO TUTORIAL: CONFIGURING 14 PIN ELECTRICAL HARNESS



CONNECTING HARNESS TO HYDRAULIC BLOCK

CONNECTING SOLENOID WIRES TO HYDRAULIC BLOCK

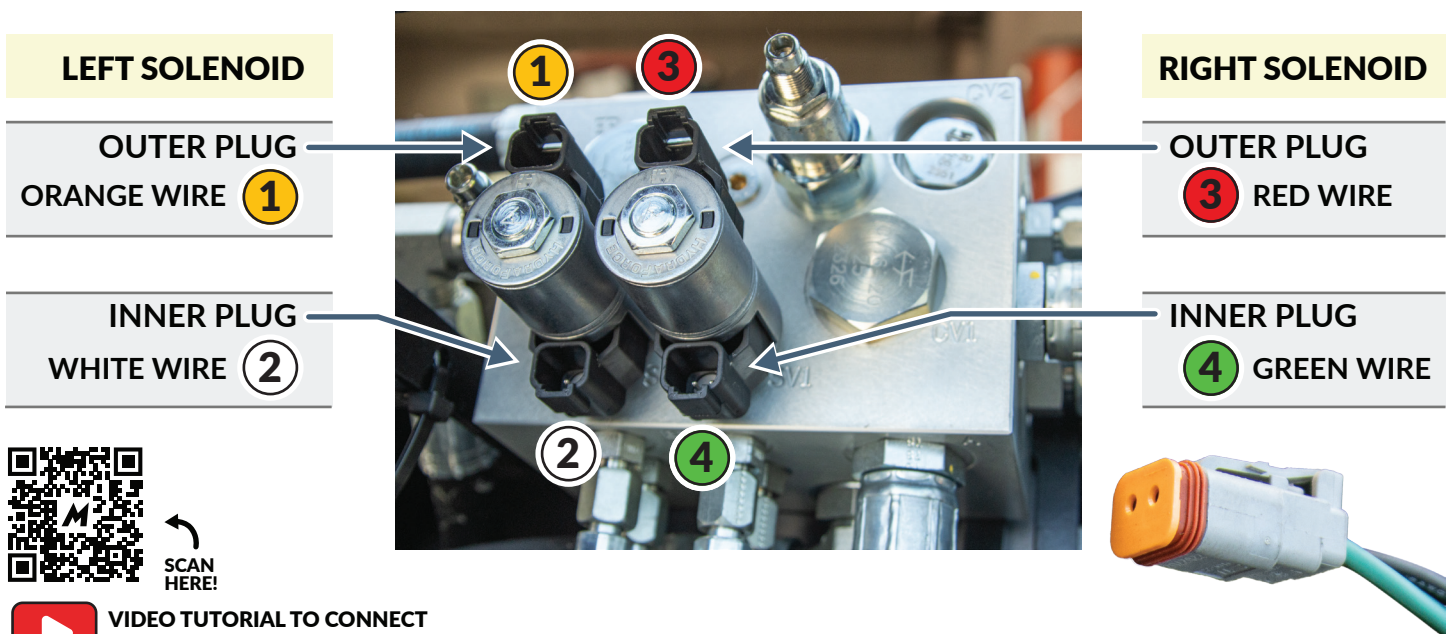

WIRING HARNESS SETUP



Wire Color	WHITE (2)	ORANGE (1)	GREEN (4)	RED (3)	
Location of plugs on hydraulic block	Left Solenoid: Inner Plug Wire FN:Deflector Up	Left Solenoid: Outer Plug Wire FN:Deflector Down	Right Solenoid: Inner Plug Wire FN: Rotate Right	Right Solenoid: Outer Plug Wire FN:Rotate Left	
Brand, Color of cell is tape color on harness	Location of pins in the 14 pin aluminum loader plug				Ground Wire
Bobcat	E	F	G	H	B
John Deere	E	D	C	G	A
CAT	D	C	F	E	B, If XPS:(K) If XHP:(N)
Kubota	G	H	F	E	B
JCB	E	F	G	H	B
Volvo	E	F	G	H	B
New Holland	D	C	E	F	B
Case	D	C	E	F	B
Wacker	E	F	D	C	B
Takeuchi	E	F	D	C	B
Joystick Controller	E	F	D	C	B
ASV (8 PIN)	G (red wire)	B (white wire)	C (green wire)	D (orange wire)	A

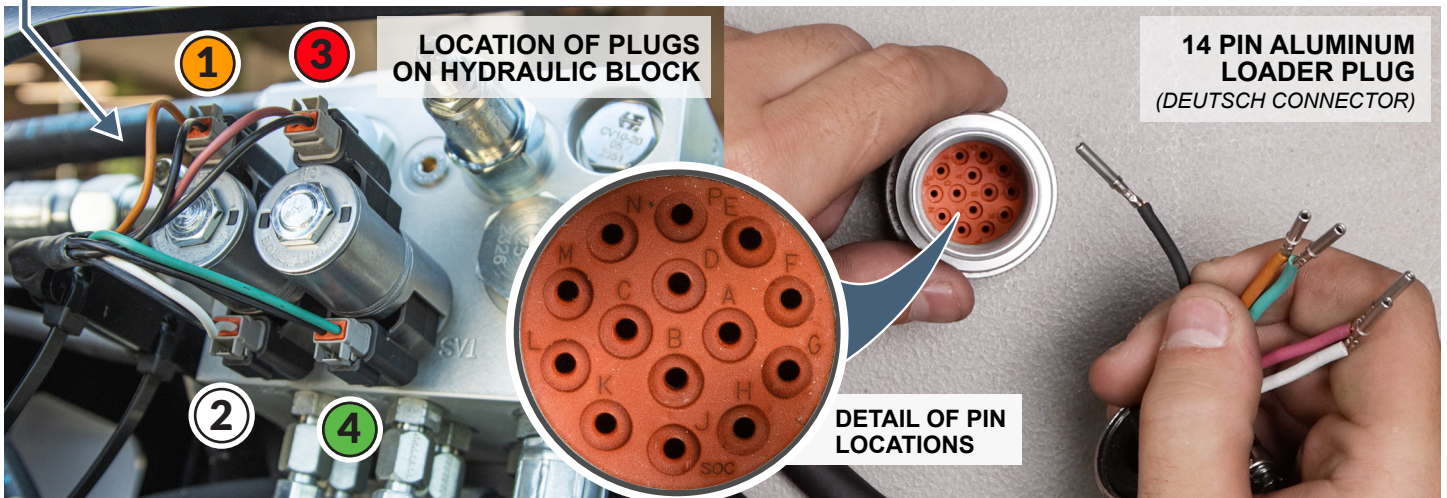

HYDRAULICS - CONTROL BLOCK ASSY

FOR MODEL

MODEL 25-60 ▼

MODEL 25-78 ▼

MODEL 25-90 ▼

PROPRIETARY AND CONFIDENTIAL

The information contained in this drawing is the sole property of Muskox. Any reproduction in part or as a whole without the written permission of Muskox is prohibited.

60"-24",CONTROL BLOCK-VALVE/HOSE ASSY 700-0123

INCLUDES ALL OF THE FOLLOWING

- BLOCK,CONTROL-2 VALVE
QUANTITY: 1
- FITTING,6MJ-8MORB STRAIGHT
QUANTITY: 1
- FITTING,12MJ-12MORB STRAIGHT
QUANTITY: 1
- FITTING,12MJ-16MORB STRAIGHT
QUANTITY: 1
- FITTING,12MJ-12MORB-90 DEG
QUANTITY: 2
- FITTING,6MJ-6MORB STRAIGHT
QUANTITY: 2
- FITTING,6MJ-6MORB STRAIGHT-.031 ORIFICE
QUANTITY: 2
- GEROLLER MOTOR FITTINGS
700-1007 QUANTITY: 1
 - FITTING,12MJ-12MORB STRAIGHT
QUANTITY: 1
 - FITTING,12MJ-12MORB-90 DEG
QUANTITY: 1
 - FITTING,6MJ-4MORB-90 DEG
QUANTITY: 1
- ALSO INCLUDES ALL PARTS LISTED BELOW

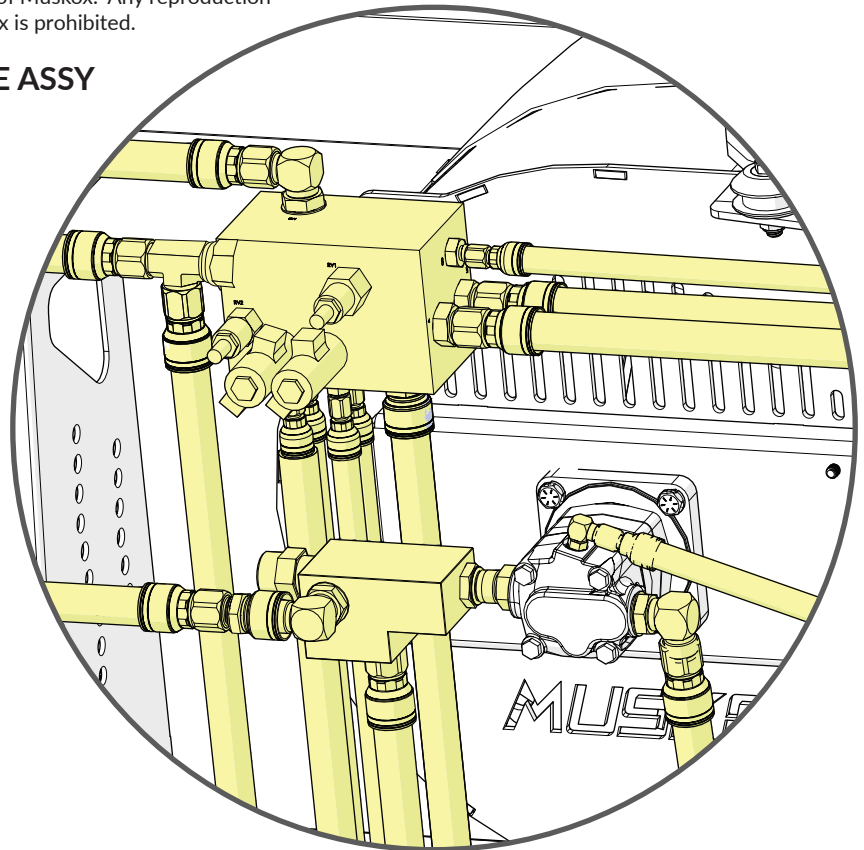

INDIVIDUAL PARTS AVAILABLE

LOADER HOSES

- FOR STANDARD LOADERS
SEE PAGE 24
- FOR BOBCAT LOADERS
SEE PAGE 25
- FOR RIGHT SIDE/SINGLE ARM LOADERS
SEE PAGE 26
- AUGER FLOW CONTROL,
BLOCK-VALVE/HOSE ASSY (SEE PAGE 22 FOR DETAILS)
700-0126 QUANTITY: 1
INCLUDES: HOSE,FAN-34"-ASSY QUANTITY: 1

DEFLECTOR HOSES (SEE PAGE 20 FOR DETAILS)

- HOSE,DEFLECTOR-53"-ASSY
1809-026 QUANTITY: 1
- HOSE,DEFLECTOR-59"-ASSY
1809-027 QUANTITY: 1
- SLEEVE,HOSE-CTL-1 1/4"X48"
0809-017 QUANTITY: 1

ROTATE MOTOR HOSES (SEE PAGE 21 FOR DETAILS)

- HOSE,ROTATE-31"-ASSY
1809-025 QUANTITY: 2

IMPELLER MOTOR HOSES (SEE PAGE 22 FOR DETAILS)

- HOSE,FAN-34"-ASSY
1809-021 QUANTITY: 1
- HOSE,LARGE FAN-23"-ASSY
1809-031 QUANTITY: 1
- HOSE,CASE DRAIN-25"-ASSY
1809-028 QUANTITY: 1

AUGER MOTOR HOSES (SEE PAGE 19 FOR DETAILS)

- HOSE,AUGER-31.5"-ASSY
1809-033 QUANTITY: 1
- HOSE,AUGER-70"-ASSY
1809-032 QUANTITY: 1
- HOSE,SUPPORT-STRAP
700-0161 QUANTITY: 1

HYDRAULICS - CONTROL BLOCK ASSY

FOR MODEL

MODEL 25-60 ▼

MODEL **25-78** ▼

MODEL 25-90 ▼

PROPRIETARY AND CONFIDENTIAL

The information contained in this drawing is the sole property of Muskox. Any reproduction in part or as a whole without the written permission of Muskox is prohibited.

78"-24",CONTROL BLOCK-VALVE/HOSE ASSY 700-0124

INCLUDES ALL OF THE FOLLOWING

- BLOCK,CONTROL-2 VALVE
QUANTITY: 1
- FITTING,6MJ-8MORB STRAIGHT
QUANTITY: 1
- FITTING,12MJ-12MORB STRAIGHT
QUANTITY: 1
- FITTING,12MJ-16MORB STRAIGHT
QUANTITY: 1
- FITTING,12MJ-12MORB-90 DEG
QUANTITY: 2
- FITTING,6MJ-6MORB STRAIGHT
QUANTITY: 2
- FITTING,6MJ-6MORB STRAIGHT-.031 ORIFICE
QUANTITY: 2
- GEROLLER MOTOR FITTINGS
700-1007 QUANTITY: 1
 - FITTING,12MJ-12MORB STRAIGHT
QUANTITY: 1
 - FITTING,12MJ-12MORB-90 DEG
QUANTITY: 1
 - FITTING,6MJ-4MORB-90 DEG
QUANTITY: 1
- ALSO INCLUDES ALL PARTS LISTED BELOW

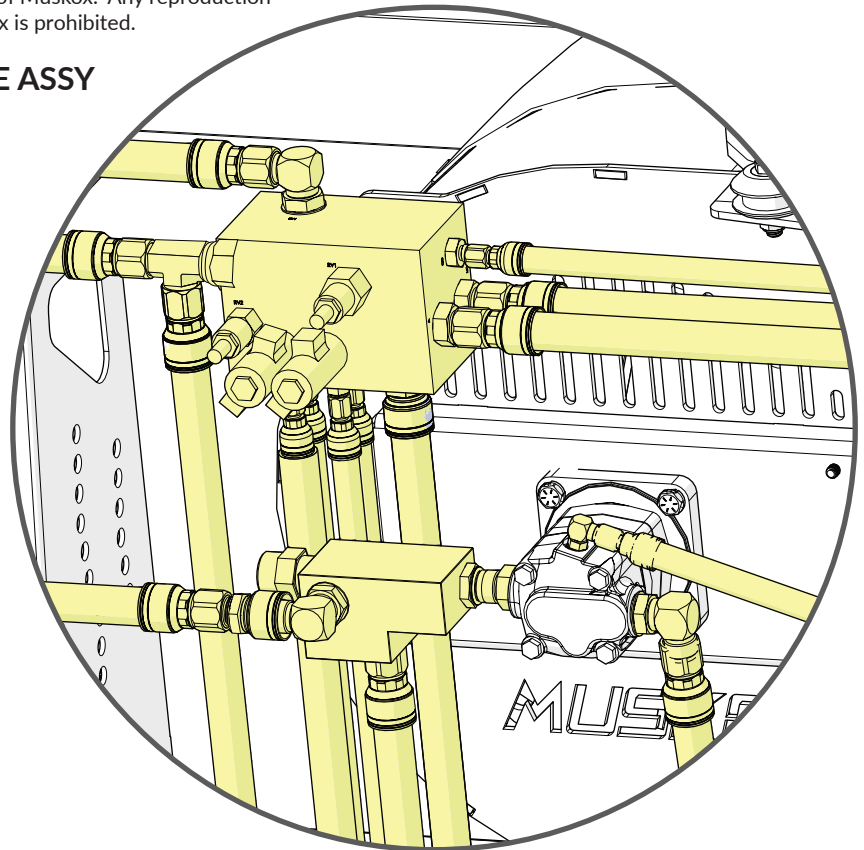

INDIVIDUAL PARTS AVAILABLE

LOADER HOSES

- FOR STANDARD LOADERS
SEE PAGE 24
- FOR BOBCAT LOADERS
SEE PAGE 25
- FOR RIGHT SIDE/SINGLE ARM LOADERS
SEE PAGE 26
- AUGER FLOW CONTROL,
BLOCK-VALVE/HOSE ASSY *(SEE PAGE 22 FOR DETAILS)*
700-0126 QUANTITY: 1
INCLUDES: HOSE,FAN-34"-ASSY QUANTITY: 1

DEFLECTOR HOSES *(SEE PAGE 20 FOR DETAILS)*

- HOSE,DEFLECTOR-53"-ASSY
1809-026 QUANTITY: 1
- HOSE,DEFLECTOR-59"-ASSY
1809-027 QUANTITY: 1
- SLEEVE,HOSE-CTL-1 1/4"X48"
0809-017 QUANTITY: 1

ROTATE MOTOR HOSES *(SEE PAGE 21 FOR DETAILS)*

- HOSE,ROTATE-31"-ASSY
1809-025 QUANTITY: 2

IMPELLER MOTOR HOSES *(SEE PAGE 22 FOR DETAILS)*

- HOSE,FAN-34"-ASSY
1809-021 QUANTITY: 1
- HOSE,LARGE FAN-23"-ASSY
1809-031 QUANTITY: 1
- HOSE,CASE DRAIN-25"-ASSY
1809-028 QUANTITY: 1

AUGER MOTOR HOSES *(SEE PAGE 19 FOR DETAILS)*

- HOSE,AUGER-40.5"-ASSY
1809-019 QUANTITY: 1
- HOSE,AUGER-79"-ASSY
1809-020 QUANTITY: 1
- HOSE,SUPPORT-STRAP
700-0161 QUANTITY: 1

HYDRAULICS - CONTROL BLOCK ASSY

MODEL 25-60 ▼

MODEL 25-78 ▼

FOR MODEL
MODEL 25-90 ▼

PROPRIETARY AND CONFIDENTIAL

The information contained in this drawing is the sole property of Muskox. Any reproduction in part or as a whole without the written permission of Muskox is prohibited.

90"-24",CONTROL BLOCK-VALVE/HOSE ASSY 700-0122

INCLUDES ALL OF THE FOLLOWING

- BLOCK,CONTROL-2 VALVE
QUANTITY: 1
- FITTING,6MJ-8MORB STRAIGHT
QUANTITY: 1
- FITTING,12MJ-12MORB STRAIGHT
QUANTITY: 1
- FITTING,12MJ-16MORB STRAIGHT
QUANTITY: 1
- FITTING,12MJ-12MORB-90 DEG
QUANTITY: 2
- FITTING,6MJ-6MORB STRAIGHT
QUANTITY: 2
- FITTING,6MJ-6MORB STRAIGHT-.031 ORIFICE
QUANTITY: 2
- GEROLLER MOTOR FITTINGS
700-1007 QUANTITY: 1
 - FITTING,12MJ-12MORB STRAIGHT
QUANTITY: 1
 - FITTING,12MJ-12MORB-90 DEG
QUANTITY: 1
 - FITTING,6MJ-4MORB-90 DEG
QUANTITY: 1
- ALSO INCLUDES ALL PARTS LISTED BELOW

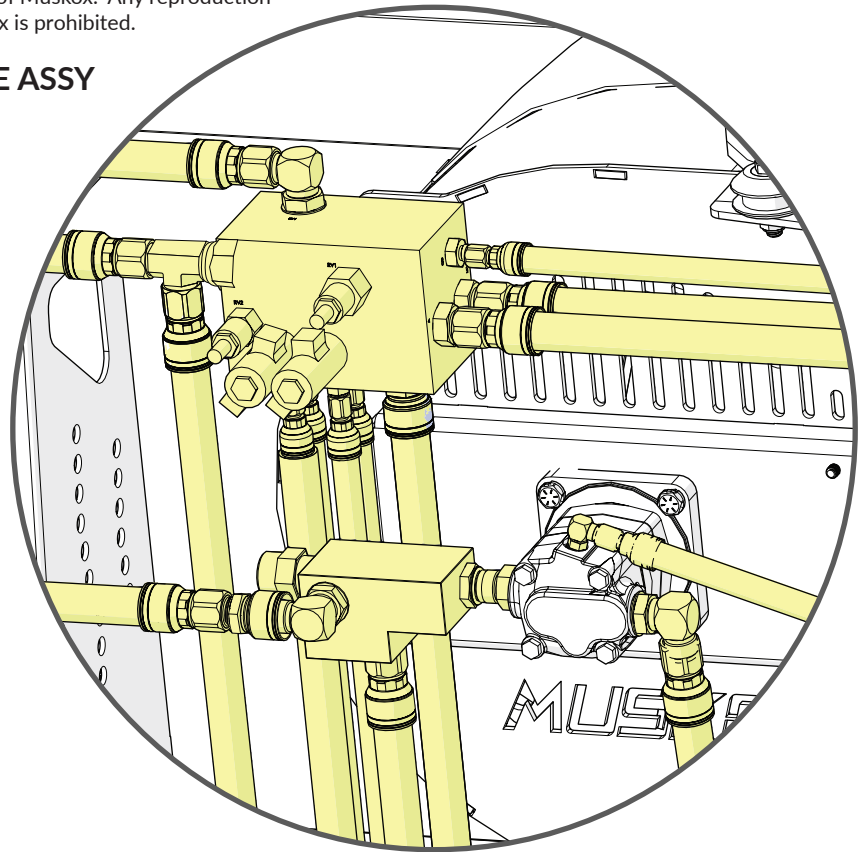

INDIVIDUAL PARTS AVAILABLE

LOADER HOSES

- FOR STANDARD LOADERS
SEE PAGE 24
- FOR BOBCAT LOADERS
SEE PAGE 25
- FOR RIGHT SIDE/SINGLE ARM LOADERS
SEE PAGE 26
- AUGER FLOW CONTROL,
BLOCK-VALVE/HOSE ASSY (SEE PAGE 22 FOR DETAILS)
700-0126 QUANTITY: 1
INCLUDES: HOSE,FAN-34"-ASSY QUANTITY: 1

DEFLECTOR HOSES (SEE PAGE 20 FOR DETAILS)

- HOSE,DEFLECTOR-53"-ASSY
1809-026 QUANTITY: 1
- HOSE,DEFLECTOR-59"-ASSY
1809-027 QUANTITY: 1
- SLEEVE,HOSE-CTL-1 1/4"X48"
0809-017 QUANTITY: 1

ROTATE MOTOR HOSES (SEE PAGE 21 FOR DETAILS)

- HOSE,ROTATE-31"-ASSY
1809-025 QUANTITY: 2

IMPELLER MOTOR HOSES (SEE PAGE 22 FOR DETAILS)

- HOSE,FAN-34"-ASSY
1809-021 QUANTITY: 1
- HOSE,LARGE FAN-23"-ASSY
1809-031 QUANTITY: 1
- HOSE,CASE DRAIN-25"-ASSY
1809-028 QUANTITY: 1

AUGER MOTOR HOSES (SEE PAGE 19 FOR DETAILS)

- HOSE,AUGER-45.5"-ASSY
1809-029 QUANTITY: 1
- HOSE,AUGER-84"-ASSY
1809-030 QUANTITY: 1
- HOSE,SUPPORT-STRAP
700-0161 QUANTITY: 1

HYDRAULICS - AUGER HOSES

FOR ALL MODELS

MODEL 25-60 ▼

MODEL 25-78 ▼

MODEL 25-90 ▼

PROPRIETARY AND CONFIDENTIAL

The information contained in this drawing is the sole property of MuskoX. Any reproduction in part or as a whole without the written permission of MuskoX is prohibited.

MODEL 25-60	HOSE,AUGER-31.5"-ASSY 1809-033 QUANTITY: 1
MODEL 25-78	HOSE,AUGER-40.5"-ASSY 1809-019 QUANTITY: 1
MODEL 25-90	HOSE,AUGER-45.5"-ASSY 1809-029 QUANTITY: 1

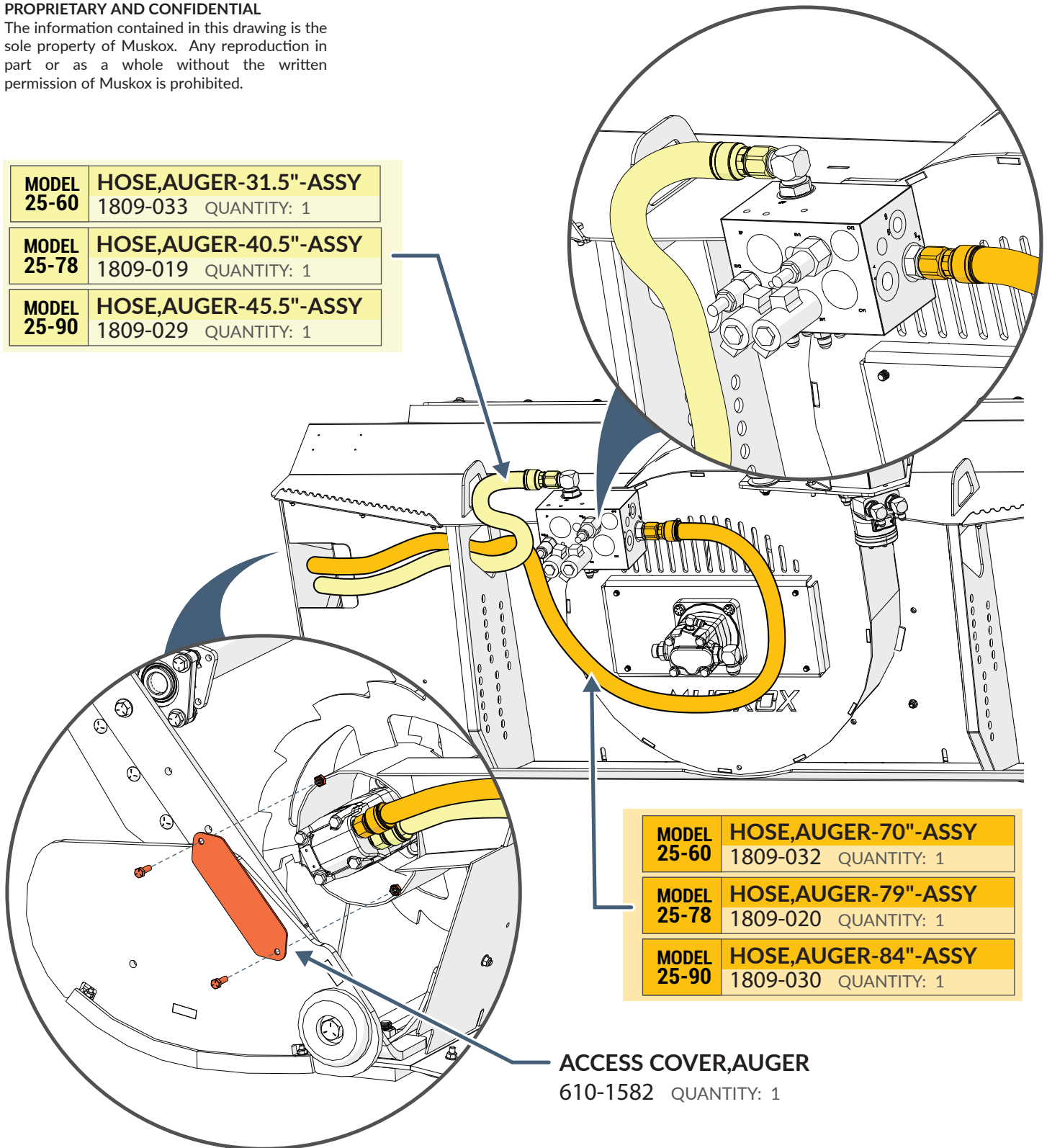

MODEL 25-60	HOSE,AUGER-70"-ASSY 1809-032 QUANTITY: 1
MODEL 25-78	HOSE,AUGER-79"-ASSY 1809-020 QUANTITY: 1
MODEL 25-90	HOSE,AUGER-84"-ASSY 1809-030 QUANTITY: 1

ACCESS COVER,AUGER
610-1582 QUANTITY: 1

HYDRAULICS - CHUTE DEFLECTION HOSES

FOR ALL MODELS

MODEL 25-60 ▼

MODEL 25-78 ▼

MODEL 25-90 ▼

PROPRIETARY AND CONFIDENTIAL

The information contained in this drawing is the sole property of Muskox. Any reproduction in part or as a whole without the written permission of Muskox is prohibited.

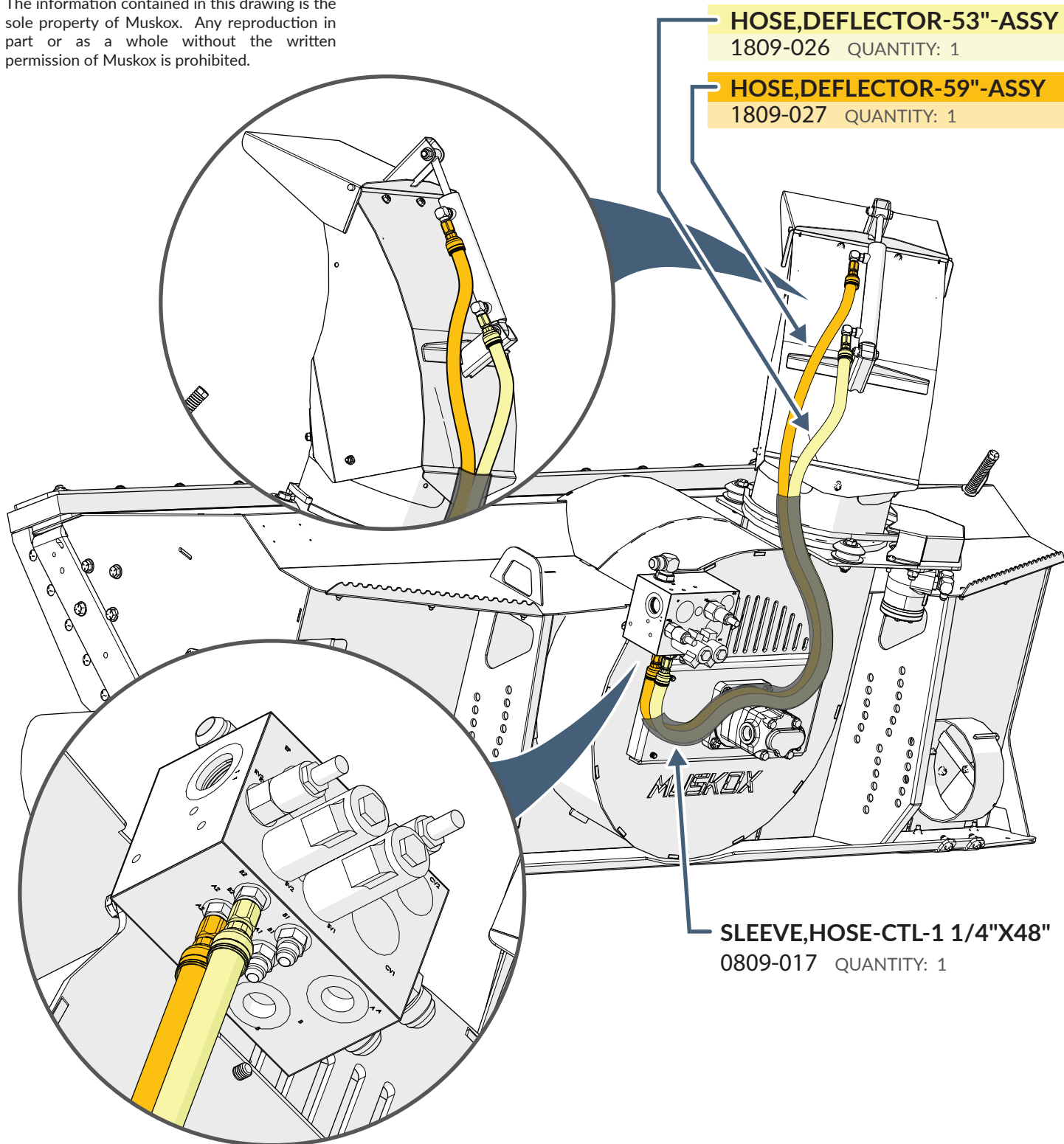

HYDRAULICS - CHUTE ROTATE HOSES

FOR ALL MODELS

MODEL 25-60 ▼

MODEL 25-78 ▼

MODEL 25-90 ▼

PROPRIETARY AND CONFIDENTIAL

The information contained in this drawing is the sole property of Muskox. Any reproduction in part or as a whole without the written permission of Muskox is prohibited.

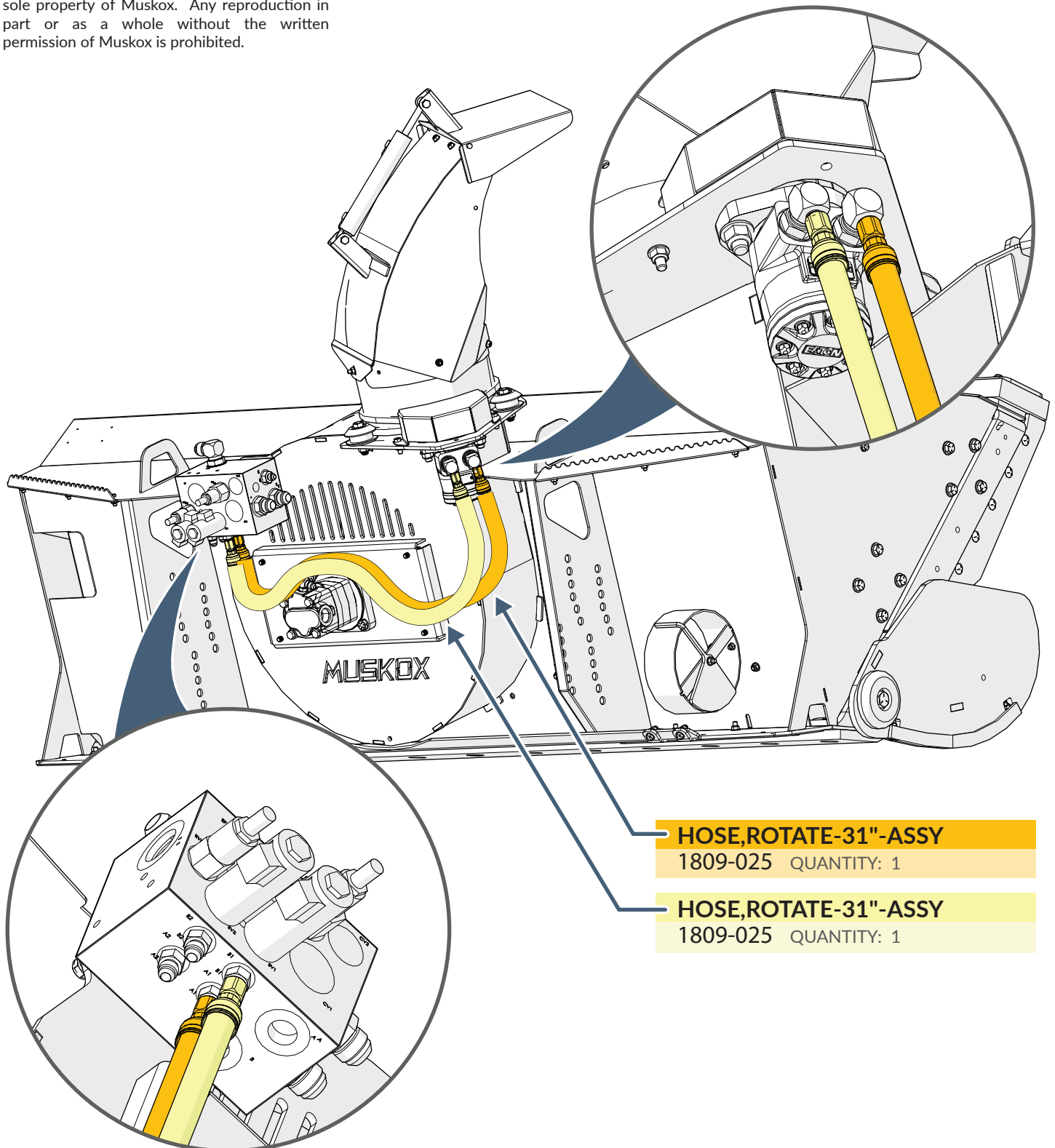

HYDRAULICS - IMPELLER MOTOR HOSES

FOR ALL MODELS

MODEL 25-60 ▼

MODEL 25-78 ▼

MODEL 25-90 ▼

PROPRIETARY AND CONFIDENTIAL

The information contained in this drawing is the sole property of Muskox. Any reproduction in part or as a whole without the written permission of Muskox is prohibited.

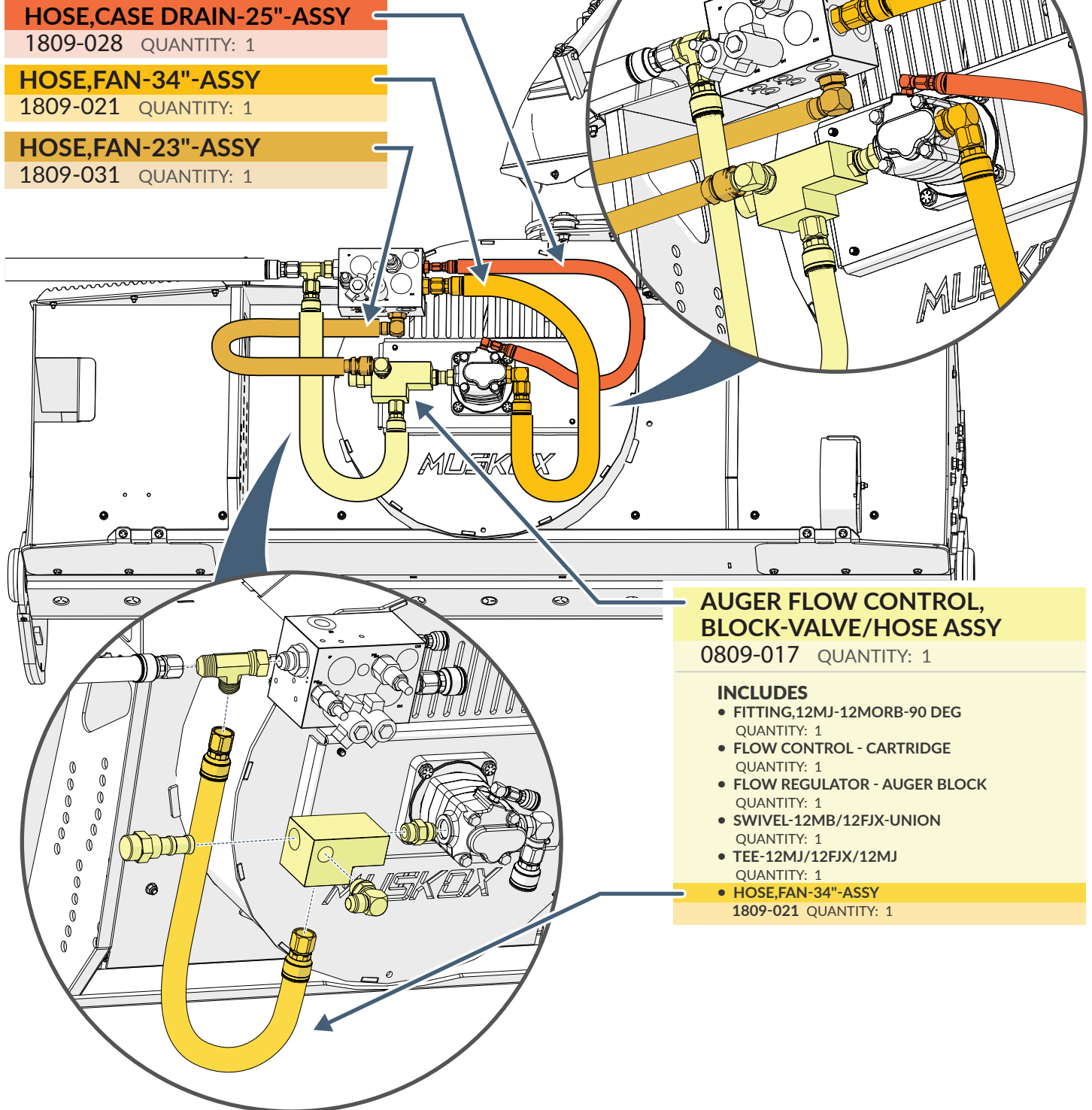

IMPELLER MOTOR

FOR ALL MODELS

MODEL 25-60 ▼

MODEL 25-78 ▼

MODEL 25-90 ▼

PROPRIETARY AND CONFIDENTIAL

The information contained in this drawing is the sole property of Muskox. Any reproduction in part or as a whole without the written permission of Muskox is prohibited.

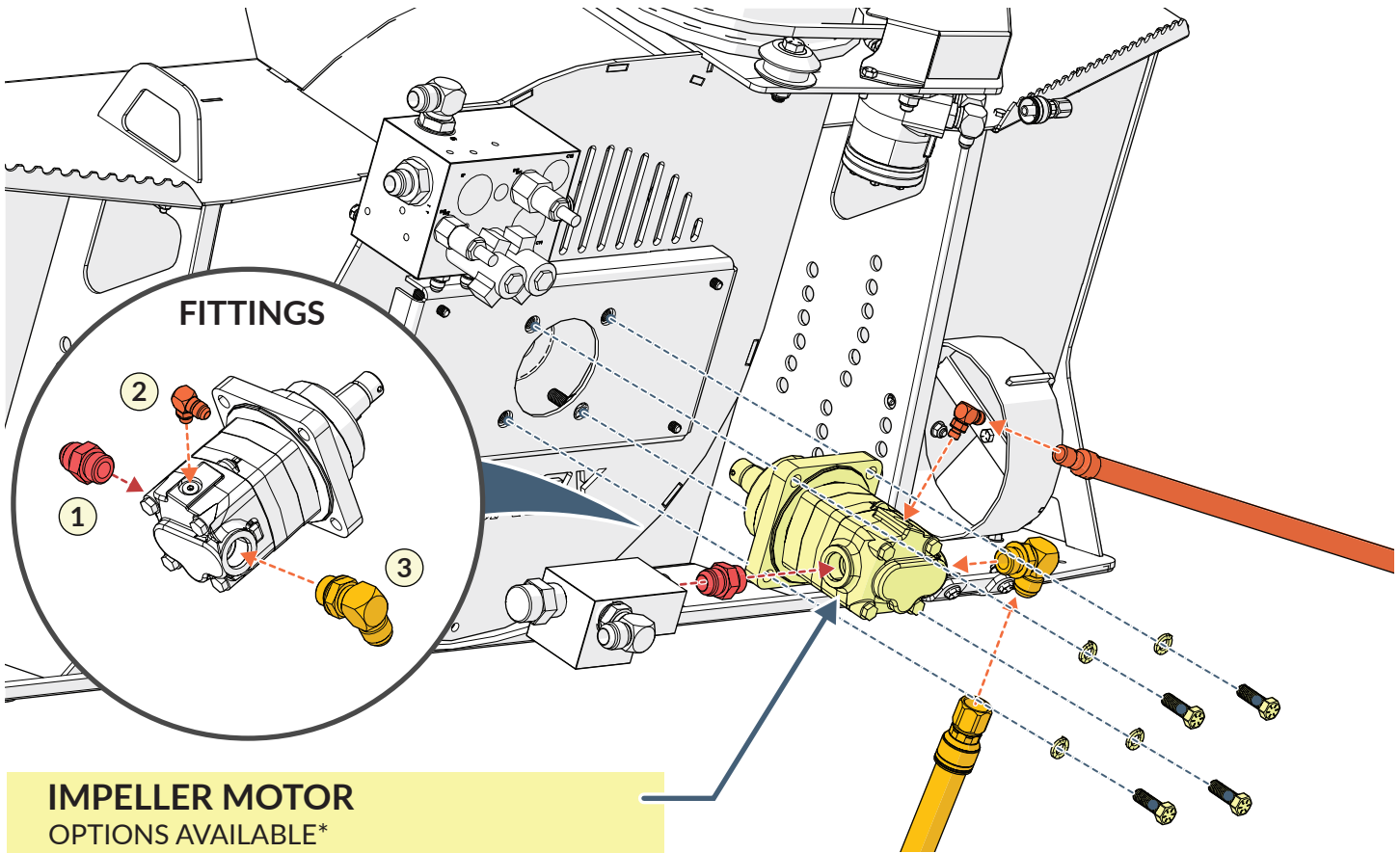

IMPELLER MOTOR

OPTIONS AVAILABLE*

- **MOTOR, 4.0 CU IN**
0809-626 QUANTITY: 1
- **MOTOR, 4.9 CU IN**
0809-610 QUANTITY: 1
- **MOTOR, 6.2 CU IN**
0809- QUANTITY: 1
- **MOTOR, 8.0 CU IN**
0809-606 QUANTITY: 1
- **MOTOR, 9.6 CU IN**
0809-611 QUANTITY: 1
- **MOTOR, 11.9 CU IN**
0809-616 QUANTITY: 1
- **MOTOR, 14.9 CU IN**
0809-617 QUANTITY: 1

FITTINGS

- ① ● **FITTING, 12MJ-12MORB-90 STRAIGHT**
QUANTITY: 1
- ② ● **FITTING, 6MJ-4MORB-90 DEG**
QUANTITY: 1
- ③ ● **FITTING, 12MJ-12MORB-90 DEG**
QUANTITY: 1



MODEL			GENERAL GUIDELINES	
25-60	25-78	25-90	HYDRAULIC MOTOR SIZE	GALLONS PER MINUTE
X			4.0 CU IN.*	12.5-14 GPM
X			4.9 CU IN.	15-18 GPM
X	X		6.2 CU IN. - 8.0 CU IN.	19-26.9 GPM
X	X		8.0 CU IN. - 9.6 CU IN.	27-32.9 GPM
X	X		9.6 CU IN. - 11.9 CU IN.	33-39.9 GPM
X	X		11.9 CU IN. - 14.9 CU IN.	40-45 GPM



* CONTACT MUSKOX FOR IMPELLER MOTOR SPECIFIC TO YOUR UNIT

LOADER HOSES - STANDARD

FOR ALL MODELS

MODEL 25-60 ▼

MODEL 25-78 ▼

MODEL 25-90 ▼

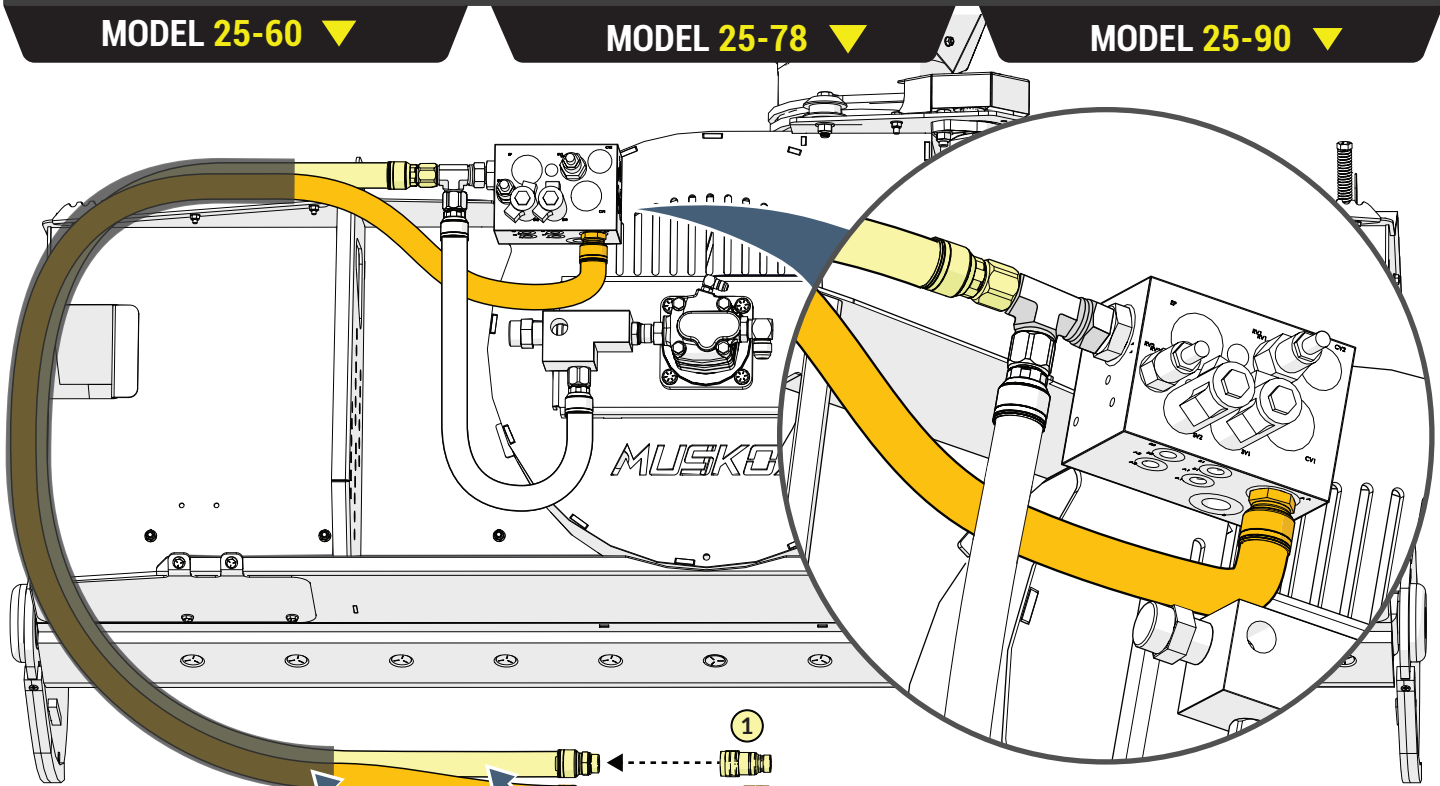

1

2

HYDRAULIC COUPLERS
(SEE BELOW)

STANDARD LOADER HOSE ASSEMBLY

HOSE,LOADER-79"-ASSY
1809-023 QUANTITY: 1

HOSE,LOADER-92"-ASSY
1809-022 QUANTITY: 1

SLEEVE,HOSE-CTL-2 1/2"X60"
0809-018 QUANTITY: 1

HOSE,SUPPORT-STRAP
700-0161 QUANTITY: 1

HYDRAULIC COUPLERS

SIZES AVAILABLE (MATCH SIZE TO THE HYDRAULIC PORTS ON YOUR LOADER)

1

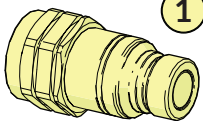

- SIZE 12, COUPLER, QUICK-MALE 1/2"-12 ORB
0809-721 QUANTITY: 1
- SIZE 16, COUPLER, QUICK-MALE 5/8"-12 ORB
0809-727 QUANTITY: 1
- SIZE 19, COUPLER, QUICK-MALE 3/4"-12 ORB
0809-729 QUANTITY: 1

2

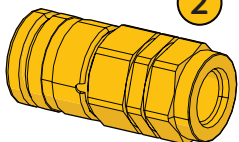

- SIZE 12, COUPLER, QUICK-FEMALE 1/2"-12 ORB
0809-720 QUANTITY: 1
- SIZE 16, COUPLER, QUICK-FEMALE 5/8"-12 ORB
0809-726 QUANTITY: 1
- SIZE 19, COUPLER, QUICK-FEMALE 3/4"-12 ORB
0809-728 QUANTITY: 1

PROPRIETARY AND CONFIDENTIAL

The information contained in this drawing is the sole property of MuskoX. Any reproduction in part or as a whole without the written permission of MuskoX is prohibited.

LOADER HOSES - BOBCAT

FOR ALL MODELS

MODEL 25-60 ▼

MODEL 25-78 ▼

MODEL 25-90 ▼

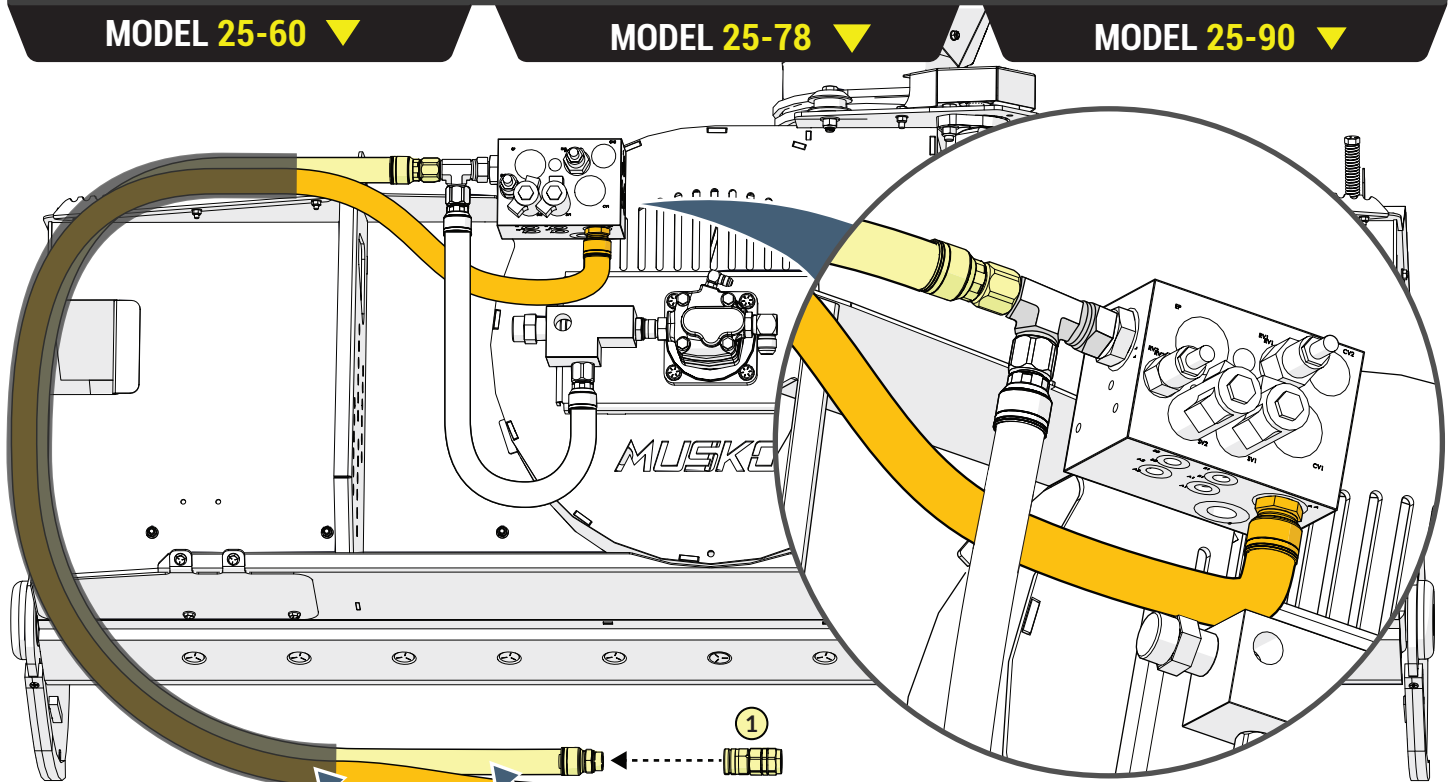

HYDRAULIC COUPLERS
(SEE BELOW)

BOBCAT LOADER HOSE ASSEMBLY

HOSE, LOADER-79"-ASSY

1809-023 QUANTITY: 1

HOSE, LOADER-92"-ASSY

1809-022 QUANTITY: 1

SLEEVE, HOSE-CTL-2 1/2"X60"

0809-018 QUANTITY: 1

HOSE, SUPPORT-STRAP

700-0161 QUANTITY: 1



NOTE:
BOBCAT HYDRAULIC
COUPLERS ARE SET UP
DIFFERENTLY FROM
OTHER BRAND LOADERS

HYDRAULIC COUPLERS

SIZES AVAILABLE
(MATCH SIZE TO THE HYDRAULIC PORTS ON YOUR LOADER)

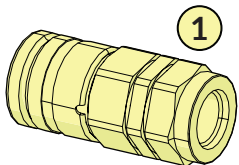

- **SIZE 12, COUPLER, QUICK-FEMALE 1/2"-12 ORB**
0809-720 QUANTITY: 1
- **SIZE 16, COUPLER, QUICK-FEMALE 5/8"-12 ORB**
0809-726 QUANTITY: 1
- **SIZE 19, COUPLER, QUICK-FEMALE 3/4"-12 ORB**
0809-728 QUANTITY: 1

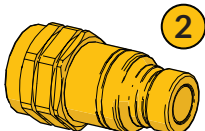

- **SIZE 12, COUPLER, QUICK-MALE 1/2"-12 ORB**
0809-721 QUANTITY: 1
- **SIZE 16, COUPLER, QUICK-MALE 5/8"-12 ORB**
0809-727 QUANTITY: 1
- **SIZE 19, COUPLER, QUICK-MALE 3/4"-12 ORB**
0809-729 QUANTITY: 1

PROPRIETARY AND CONFIDENTIAL

The information contained in this drawing is the sole property of Muskox. Any reproduction in part or as a whole without the written permission of Muskox is prohibited.

LOADER HOSES - SINGLE ARM / RIGHT SIDE

FOR ALL MODELS

MODEL 25-60 ▼

MODEL 25-78 ▼

MODEL 25-90 ▼

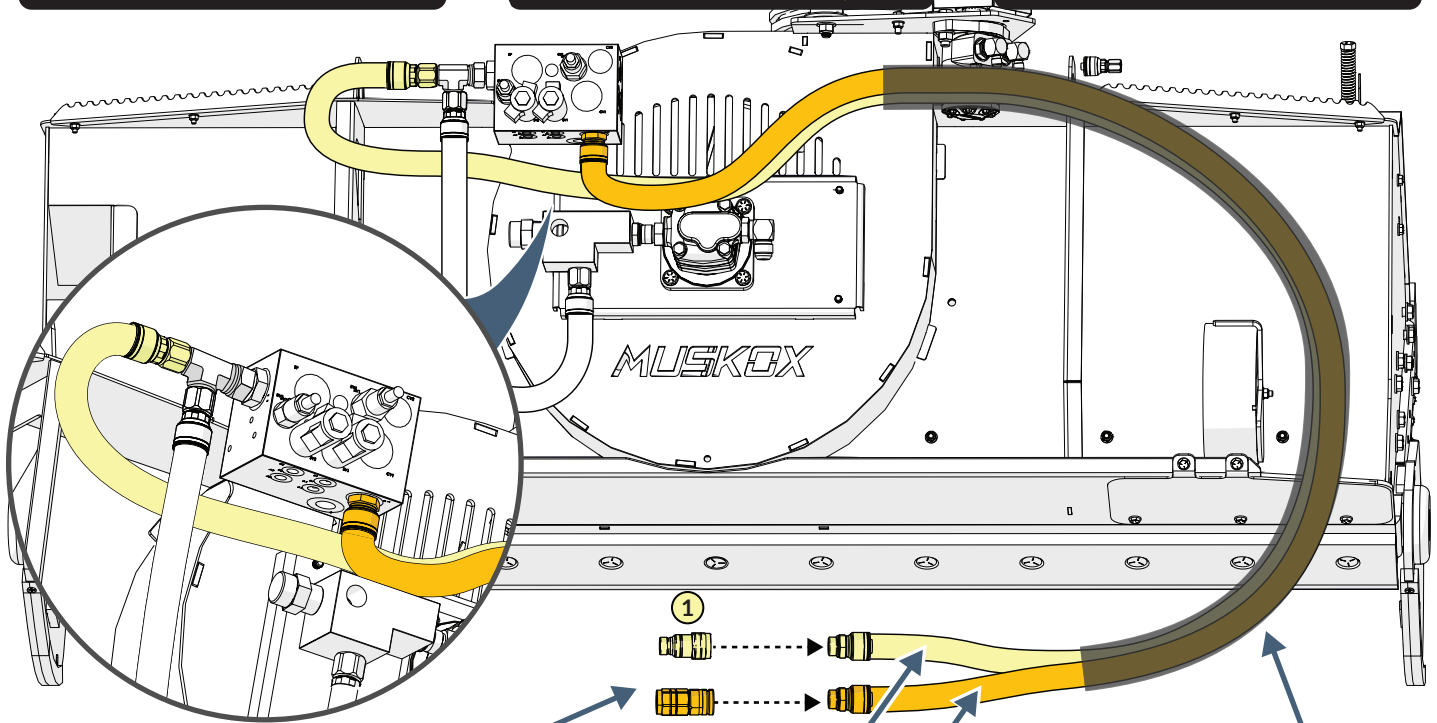

HYDRAULIC COUPLERS
(SEE BELOW)

SINGLE ARM LOADER HOSE ASSEMBLY

HOSE,LOADER-124"-ASSY

1809-024 QUANTITY: 1

HOSE,LOADER-92"-ASSY

1809-022 QUANTITY: 1

①



②



SLEEVE,HOSE-CTL-
2 1/2"X60"

0809-018 QUANTITY: 1

HOSE,SUPPORT-STRAP

700-0161 QUANTITY: 1

HYDRAULIC COUPLERS

SIZES AVAILABLE

(MATCH SIZE TO THE HYDRAULIC PORTS ON YOUR LOADER)

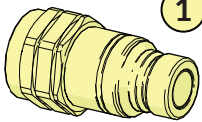

①

- SIZE 12, COUPLER, QUICK-MALE 1/2"-12 ORB
0809-721 QUANTITY: 1
- SIZE 16, COUPLER, QUICK-MALE 5/8"-12 ORB
0809-727 QUANTITY: 1
- SIZE 19, COUPLER, QUICK-MALE 3/4"-12 ORB
0809-729 QUANTITY: 1

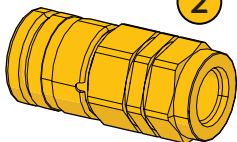

②

- SIZE 12, COUPLER, QUICK-FEMALE 1/2"-12 ORB
0809-720 QUANTITY: 1
- SIZE 16, COUPLER, QUICK-FEMALE 5/8"-12 ORB
0809-726 QUANTITY: 1
- SIZE 19, COUPLER, QUICK-FEMALE 3/4"-12 ORB
0809-728 QUANTITY: 1

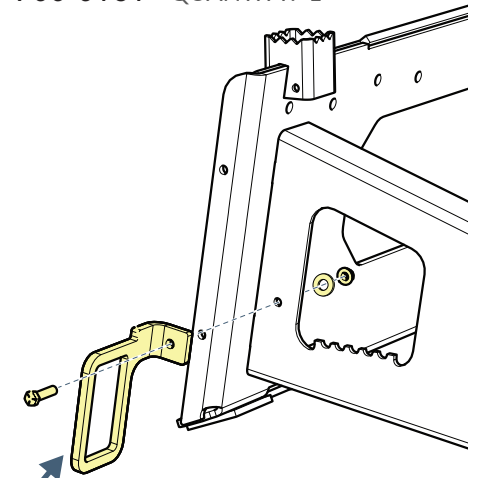

RIGHT SIDE HOSE LOOP KIT

700-1517 QUANTITY: 1

INCLUDES

- LOOP, HOSE, RIGHT SIDE
QUANTITY: 1
- BOLT,HEX-3/8"X1 1/2"-GR5 Z&C
QUANTITY: 1
- NUT,FLG NYL-3/8"-Z&C
QUANTITY: 1
- WASHER,FLAT,SAE-3/8"-Z&C
QUANTITY: 1

PROPRIETARY AND CONFIDENTIAL

The information contained in this drawing is the sole property of MuskoX. Any reproduction in part or as a whole without the written permission of MuskoX is prohibited.

IMPELLER

FOR ALL MODELS

MODEL 25-60 ▼

MODEL 25-78 ▼

MODEL 25-90 ▼

PROPRIETARY AND CONFIDENTIAL

The information contained in this drawing is the sole property of MuskoX. Any reproduction in part or as a whole without the written permission of MuskoX is prohibited.

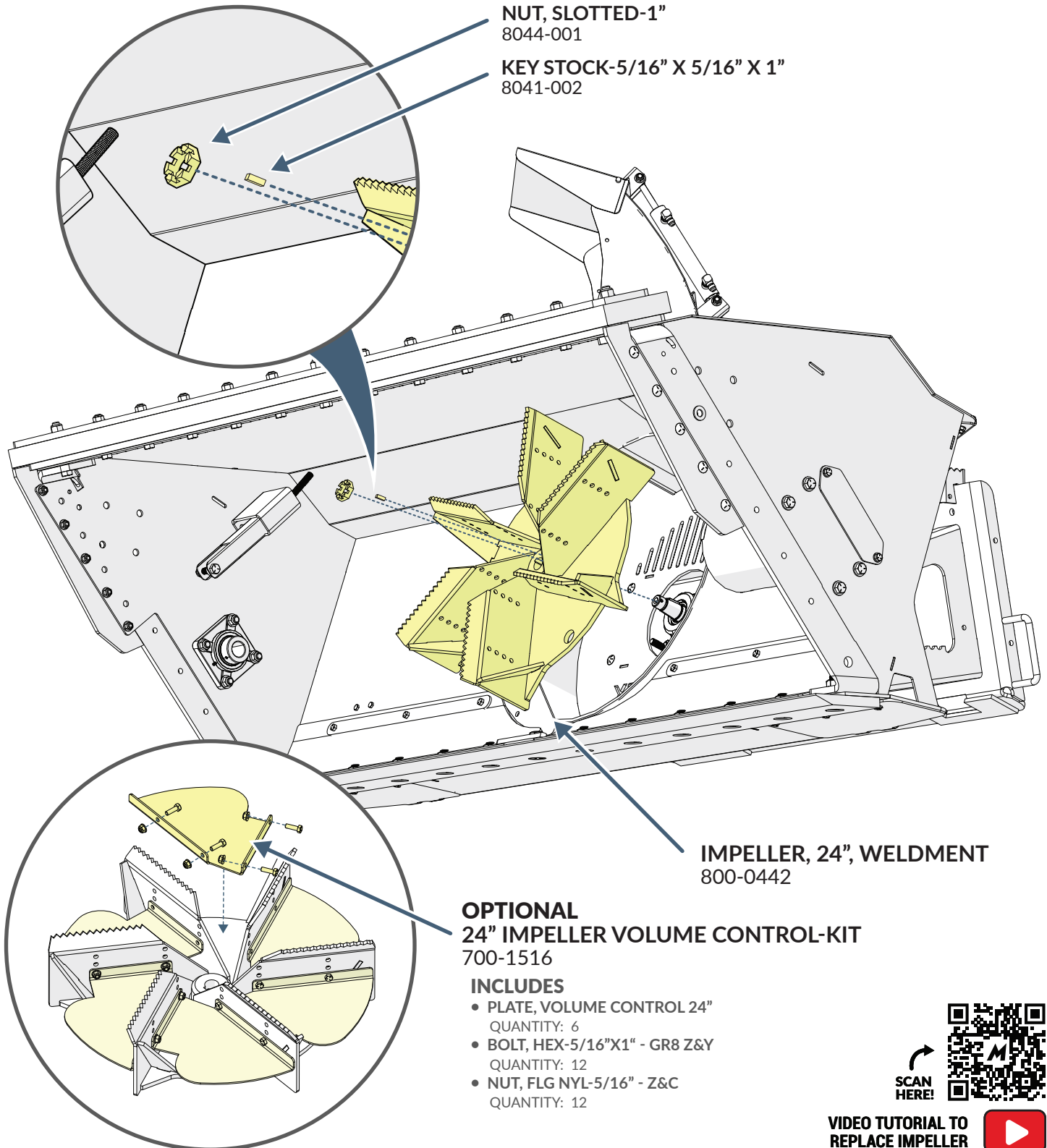

LEVELING WHEEL

FOR ALL MODELS

MODEL 25-60 ▼

MODEL 25-78 ▼

MODEL 25-90 ▼

PROPRIETARY AND CONFIDENTIAL

The information contained in this drawing is the sole property of Muskox. Any reproduction in part or as a whole without the written permission of Muskox is prohibited.

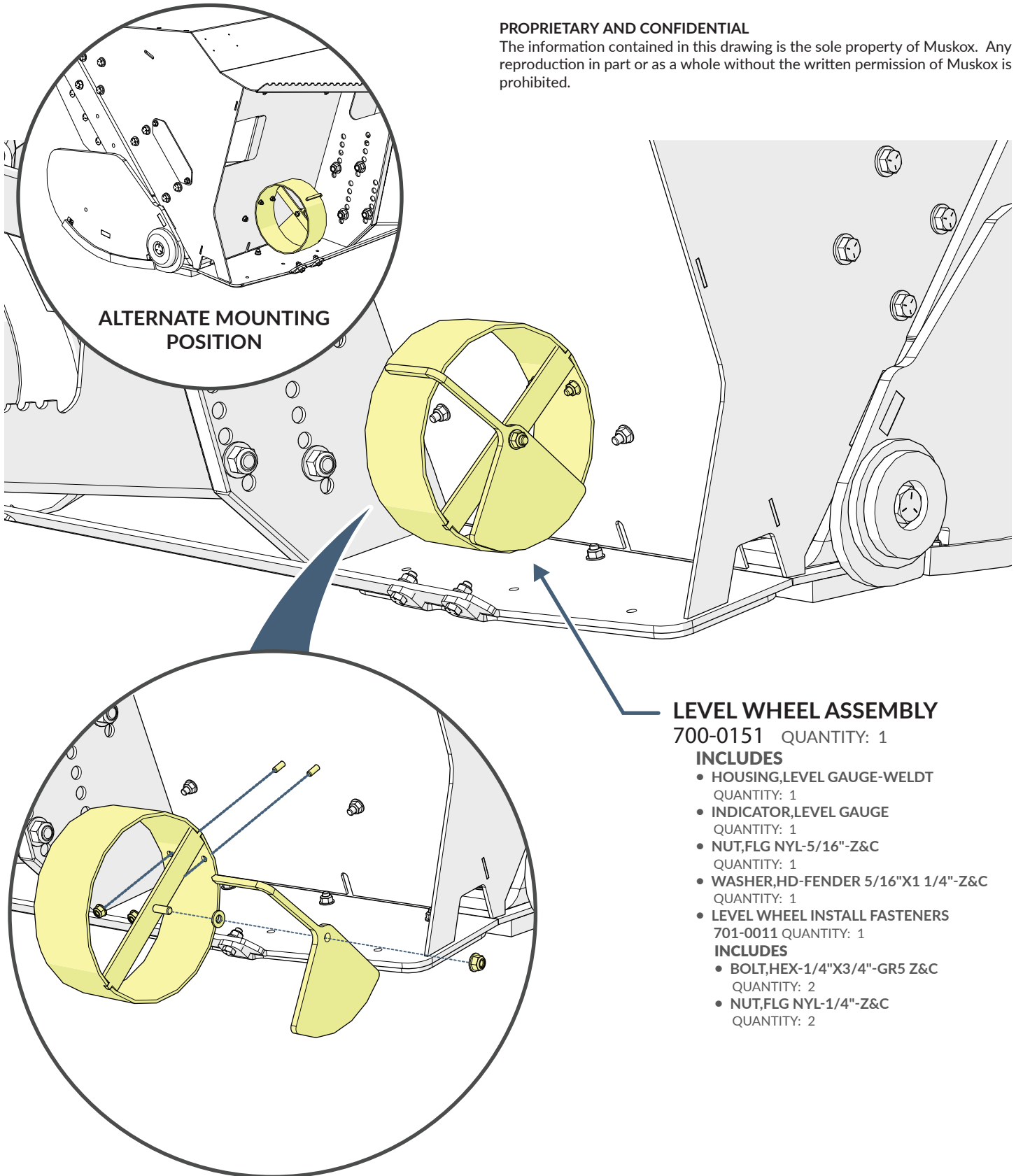

ALTERNATE MOUNTING
POSITION

LEVEL WHEEL ASSEMBLY

700-0151 QUANTITY: 1

INCLUDES

- HOUSING,LEVEL GAUGE-WELDT
QUANTITY: 1
 - INDICATOR,LEVEL GAUGE
QUANTITY: 1
 - NUT,FLG NYL-5/16"-Z&C
QUANTITY: 1
 - WASHER,HD-FENDER 5/16"X1 1/4"-Z&C
QUANTITY: 1
 - LEVEL WHEEL INSTALL FASTENERS
701-0011 QUANTITY: 1
- ### INCLUDES
- BOLT,HEX-1/4"X3/4"-GR5 Z&C
QUANTITY: 2
 - NUT,FLG NYL-1/4"-Z&C
QUANTITY: 2

LOWER AUGER

FOR MODEL

MODEL 25-60 ▼

MODEL 25-78 ▼

MODEL 25-90 ▼

LOWER AUGER, 60"-ASSY 700-2114

INCLUDES

- NUT,FLG NYL-3/8"-Z&C
QUANTITY: 4
- ZERK, GREASE-1/4 28 STRAIGHT
QUANTITY: 1
- BOLT, HEX-3/8"X1 1/2"-GR5 Z&C
QUANTITY: 4
- SPROCKET, #60-6024X, W/HOLE PATTERN
QUANTITY: 1
- FLANGE BEARING, 1 1/4" 4 BOLT-LOCK
COLLAR 207 HOUSING HCFS207-20
QUANTITY: 1
- AUGER, LOWER, 60" WELDT
QUANTITY: 1

PROPRIETARY AND CONFIDENTIAL

The information contained in this drawing is the sole property of Muskox. Any reproduction in part or as a whole without the written permission of Muskox is prohibited.

INCLUDES

- BOLT, HEX-1/2"X1 1/2"-GR5 Z&C
QUANTITY: 4
- NUT, FLG NYL-1/2"-Z&C
QUANTITY: 4
- BOLT, HEX-1/2"X1 3/4"-GR5 Z&C
QUANTITY: 4
- NUT, HEX NYL-1/2"-Z&C
QUANTITY: 4
- WASHER, FLAT, SAE-1/2"-Z&C
QUANTITY: 8

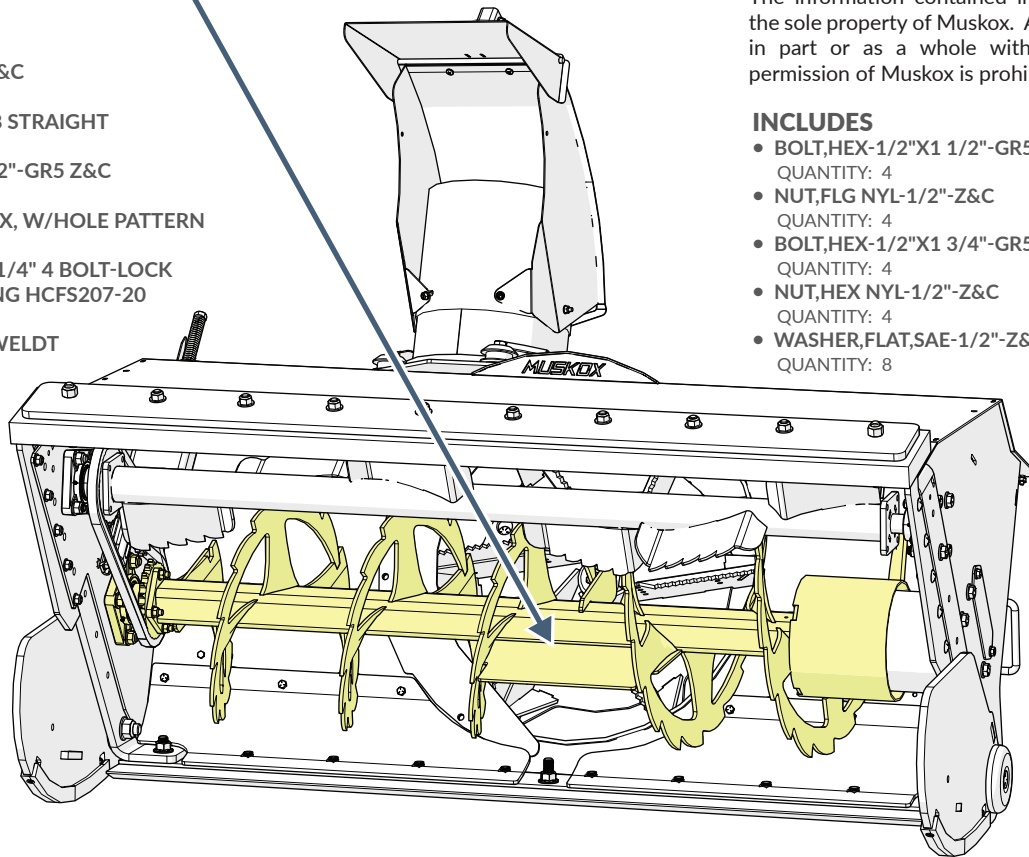

INDIVIDUAL PARTS AVAILABLE

LOWER AUGER BEARING INSTALL FASTENERS 700-0003

INCLUDES

- BOLT, HEX-1/2"X1 3/4"-GR5 Z&C
QUANTITY: 4
- NUT, FLG NYL-1/2"-Z&C
QUANTITY: 4
- WASHER, FLAT, SAE-1/2"-Z&C
QUANTITY: 4

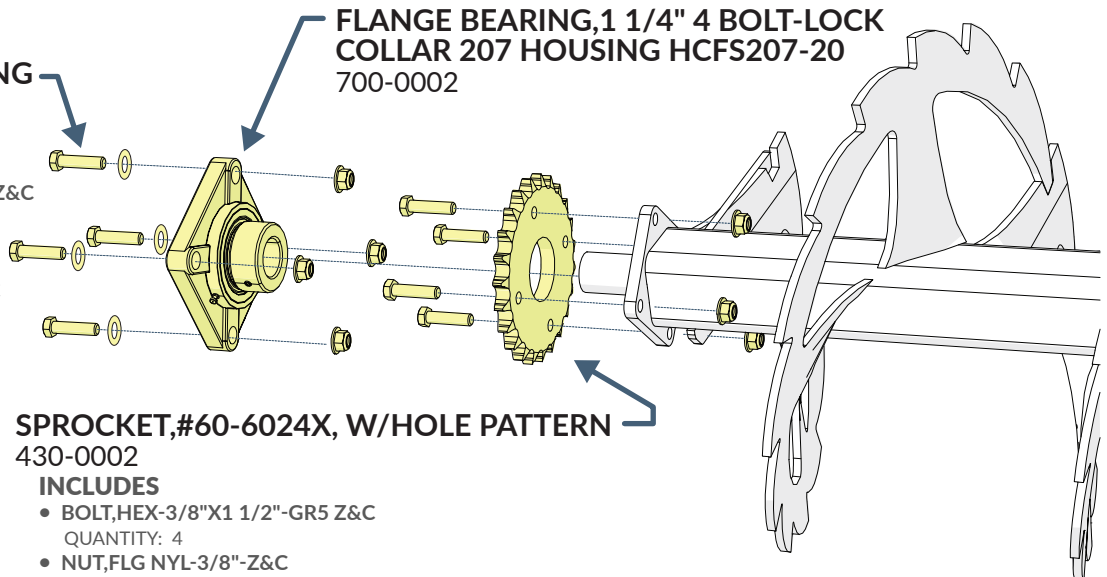

SPROCKET, #60-6024X, W/HOLE PATTERN 430-0002

INCLUDES

- BOLT, HEX-3/8"X1 1/2"-GR5 Z&C
QUANTITY: 4
- NUT, FLG NYL-3/8"-Z&C
QUANTITY: 4



SCAN
HERE!



VIDEO TUTORIAL TO REPLACE BOTTOM AUGER,
AUGER SPROCKET & BEARINGS

LOWER AUGER

MODEL 25-60 ▼

FOR MODEL

MODEL 25-78 ▼

MODEL 25-90 ▼

LOWER AUGER, 78"-ASSY 700-2012

INCLUDES

- NUT,FLG NYL-3/8"-Z&C
QUANTITY: 4
- ZERK,GREASE-1/4 28 STRAIGHT
QUANTITY: 1
- BOLT,HEX-3/8"X1 1/2"-GR5 Z&C
QUANTITY: 4
- SPROCKET,#60-6024X, W/HOLE PATTERN
QUANTITY: 1
- FLANGE BEARING,1 1/4" 4 BOLT-LOCK
COLLAR 207 HOUSING HCFS207-20
QUANTITY: 1
- AUGER,LWR SPIRAL-WELDT - 78"
QUANTITY: 1

PROPRIETARY AND CONFIDENTIAL

The information contained in this drawing is the sole property of Muskox. Any reproduction in part or as a whole without the written permission of Muskox is prohibited.

INCLUDES

- BOLT,HEX-1/2"X1 1/2"-GR5 Z&C
QUANTITY: 4
- NUT,FLG NYL-1/2"-Z&C
QUANTITY: 4
- BOLT,HEX-1/2"X1 3/4"-GR5 Z&C
QUANTITY: 4
- NUT,HEX NYL-1/2"-Z&C
QUANTITY: 4
- WASHER,FLAT,SAE-1/2"-Z&C
QUANTITY: 8

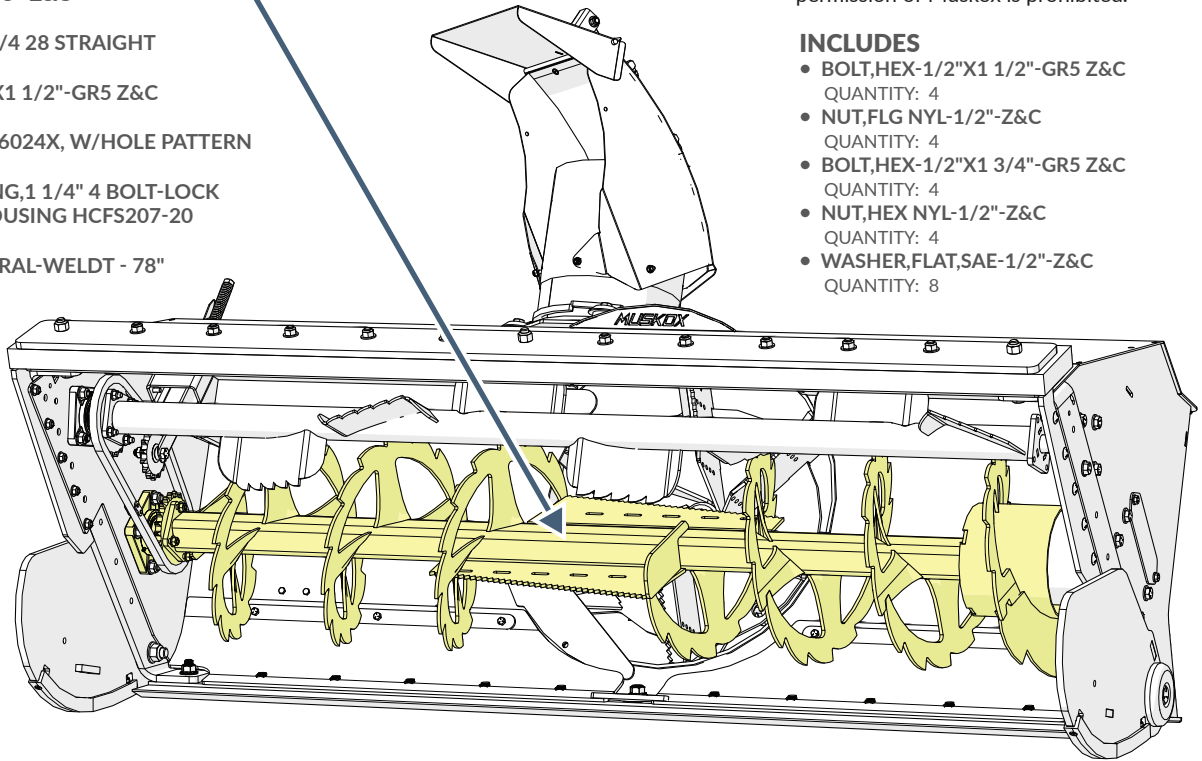

INDIVIDUAL PARTS AVAILABLE

LOWER AUGER BEARING INSTALL FASTENERS 700-0003

INCLUDES

- BOLT,HEX-1/2"X1 3/4"-GR5 Z&C
QUANTITY: 4
- NUT,FLG NYL-1/2"-Z&C
QUANTITY: 4
- WASHER,FLAT,SAE-1/2"-Z&C
QUANTITY: 4

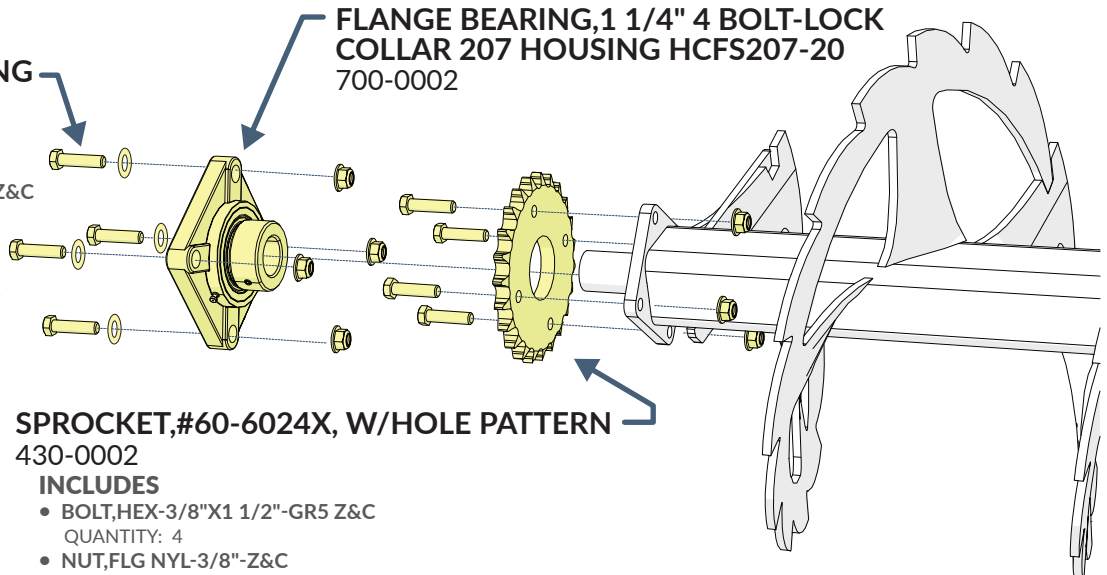

SPROCKET,#60-6024X, W/HOLE PATTERN 430-0002

INCLUDES

- BOLT,HEX-3/8"X1 1/2"-GR5 Z&C
QUANTITY: 4
- NUT,FLG NYL-3/8"-Z&C
QUANTITY: 4



SCAN
HERE!



VIDEO TUTORIAL TO REPLACE BOTTOM AUGER,
AUGER SPROCKET & BEARINGS

LOWER AUGER

MODEL 25-60 ▼

MODEL 25-78 ▼

FOR MODEL
MODEL 25-90 ▼

LOWER AUGER, 90"-ASSY 700-2113

INCLUDES

- NUT,FLG NYL-3/8"-Z&C
QUANTITY: 4
- ZERK, GREASE-1/4 28 STRAIGHT
QUANTITY: 1
- BOLT, HEX-3/8"X1 1/2"-GR5 Z&C
QUANTITY: 4
- SPROCKET, #60-6024X, W/HOLE PATTERN
QUANTITY: 1
- FLANGE BEARING, 1 1/4" 4 BOLT-LOCK
COLLAR 207 HOUSING HCFS207-20
QUANTITY: 1
- AUGER, LWR SPIRAL-WELDT - 90"
QUANTITY: 1

PROPRIETARY AND CONFIDENTIAL

The information contained in this drawing is the sole property of Muskox. Any reproduction in part or as a whole without the written permission of Muskox is prohibited.

INCLUDES

- BOLT, HEX-1/2"X1 1/2"-GR5 Z&C
QUANTITY: 4
- NUT, FLG NYL-1/2"-Z&C
QUANTITY: 4
- BOLT, HEX-1/2"X1 3/4"-GR5 Z&C
QUANTITY: 4
- NUT, HEX NYL-1/2"-Z&C
QUANTITY: 4
- WASHER, FLAT, SAE-1/2"-Z&C
QUANTITY: 8

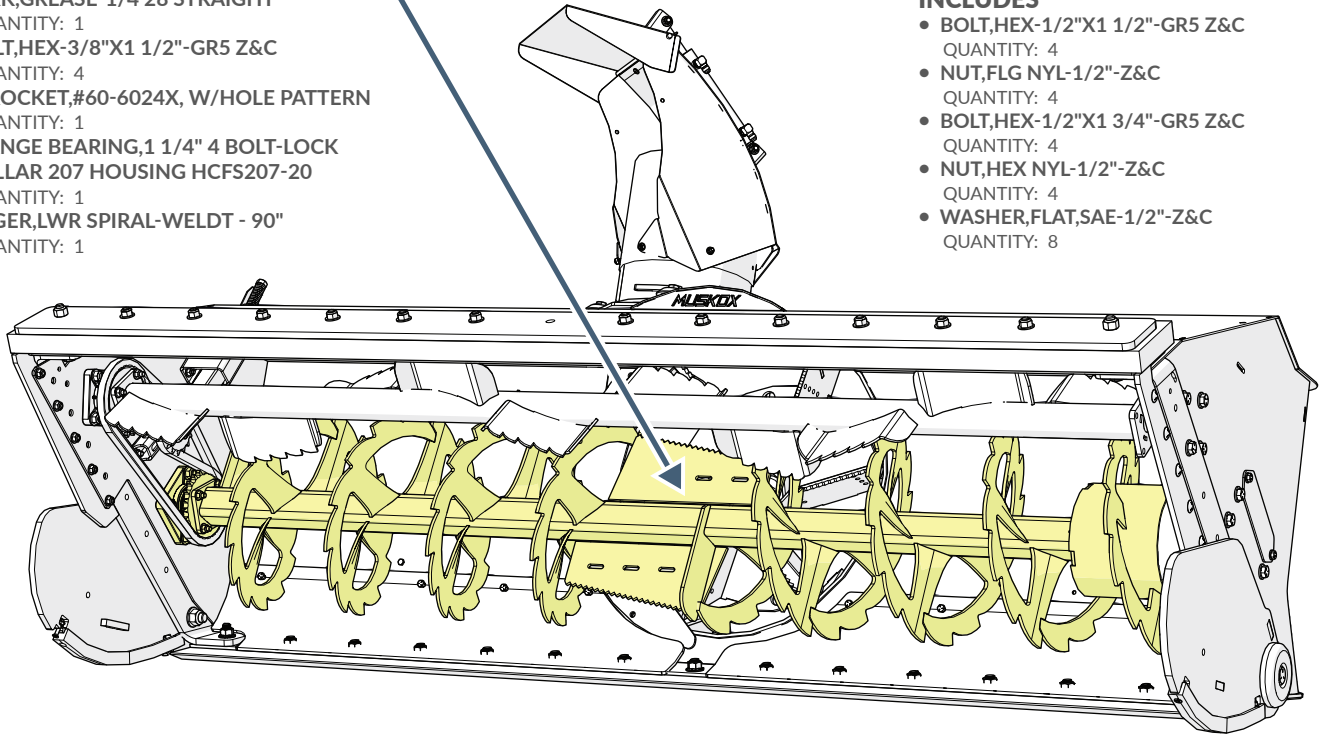

INDIVIDUAL PARTS AVAILABLE

LOWER AUGER BEARING INSTALL FASTENERS 700-0003

INCLUDES

- BOLT, HEX-1/2"X1 3/4"-GR5 Z&C
QUANTITY: 4
- NUT, FLG NYL-1/2"-Z&C
QUANTITY: 4
- WASHER, FLAT, SAE-1/2"-Z&C
QUANTITY: 4

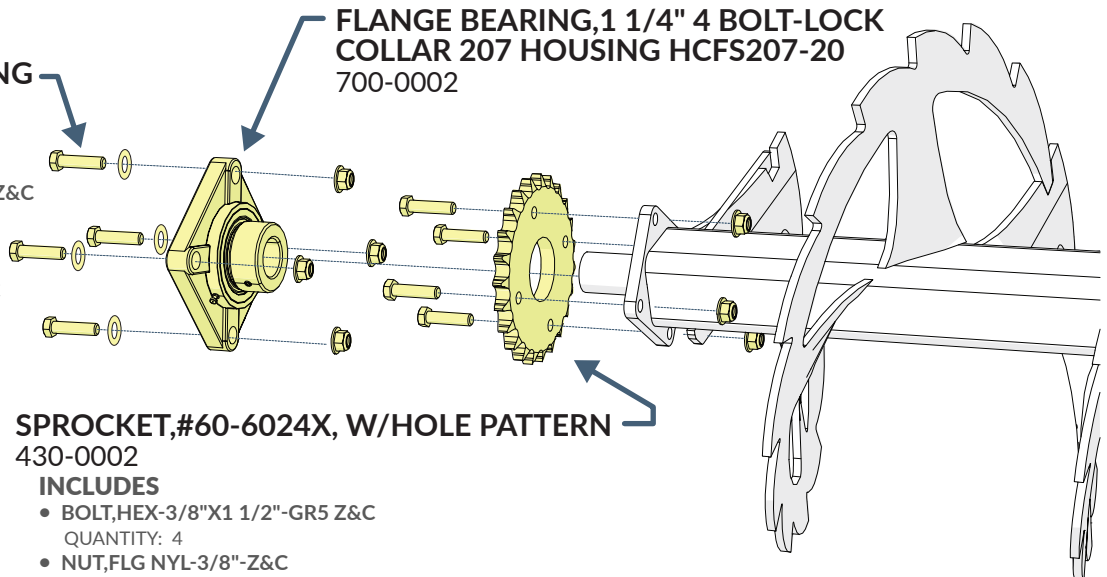

FLANGE BEARING, 1 1/4" 4 BOLT-LOCK COLLAR 207 HOUSING HCFS207-20 700-0002

SPROCKET, #60-6024X, W/HOLE PATTERN 430-0002

INCLUDES

- BOLT, HEX-3/8"X1 1/2"-GR5 Z&C
QUANTITY: 4
- NUT, FLG NYL-3/8"-Z&C
QUANTITY: 4



SCAN
HERE!



VIDEO TUTORIAL TO REPLACE BOTTOM AUGER,
AUGER SPROCKET & BEARINGS

MOUNTING PLATE

FOR ALL MODELS

MODEL 25-60 ▼

MODEL 25-78 ▼

MODEL 25-90 ▼

PROPRIETARY AND CONFIDENTIAL

The information contained in this drawing is the sole property of Muskox. Any reproduction in part or as a whole without the written permission of Muskox is prohibited.

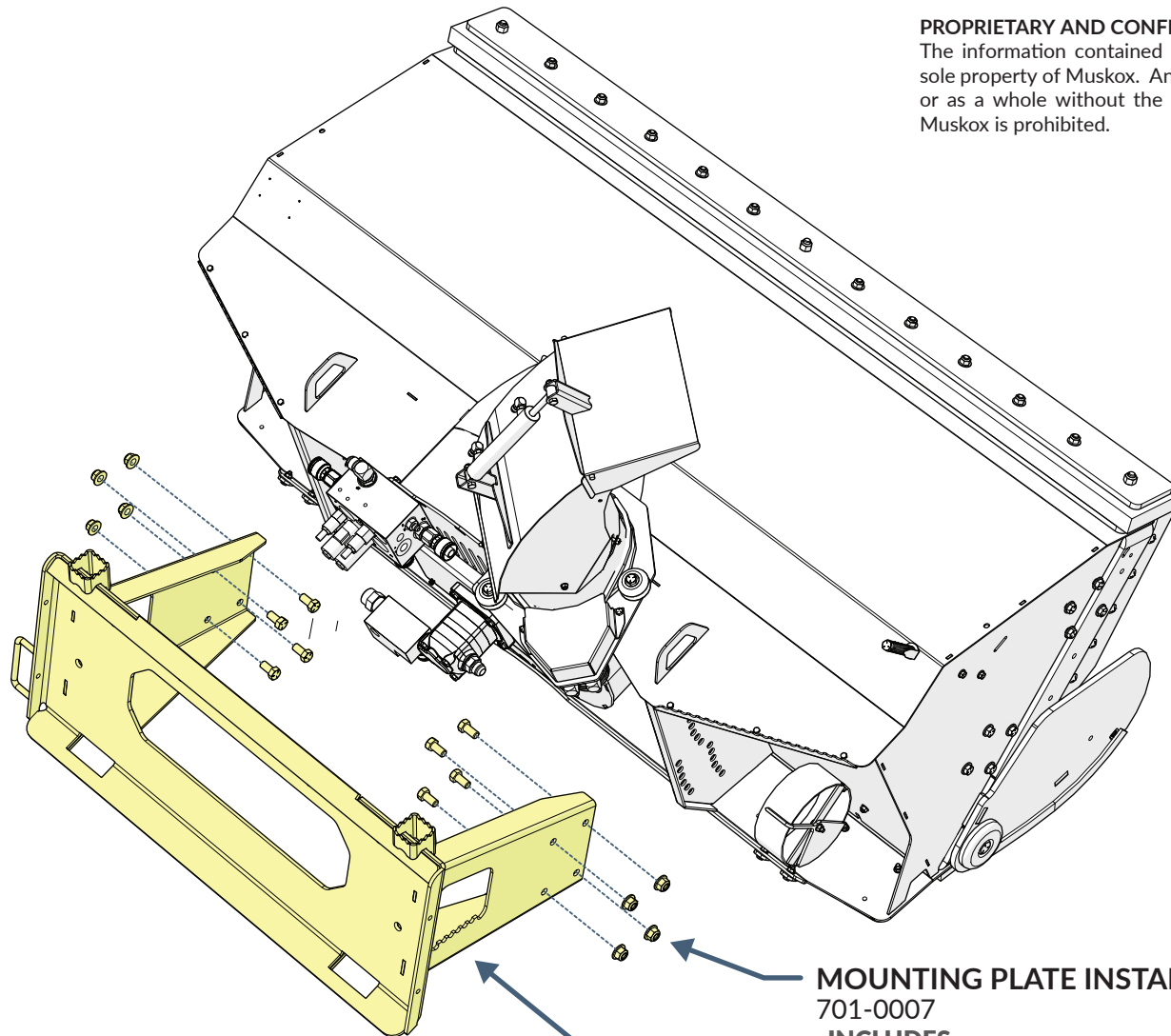

MOUNTING PLATE INSTALL FASTENERS 701-0007

INCLUDES

- NUT, FLG-TOP LOCK-5/8"-GR8-Z&C
QUANTITY: 8
- BOLT, HEX-5/8"X1 1/4"-GR8 Z&Y
QUANTITY: 8

PLATE, MNT-LOADER-WELDT 800-0426-R4

OPTIONAL (SEE PAGE 26 FOR ADDITIONAL DETAILS)

RIGHT SIDE HOSE LOOP KIT

700-1517 QUANTITY: 1

INCLUDES

- LOOP, HOSE, RIGHT SIDE
QUANTITY: 1
- BOLT, HEX-3/8"X1 1/2"-GR5 Z&C
QUANTITY: 1
- NUT, FLG NYL-3/8"-Z&C
QUANTITY: 1
- WASHER, FLAT, SAE-3/8"-Z&C
QUANTITY: 1

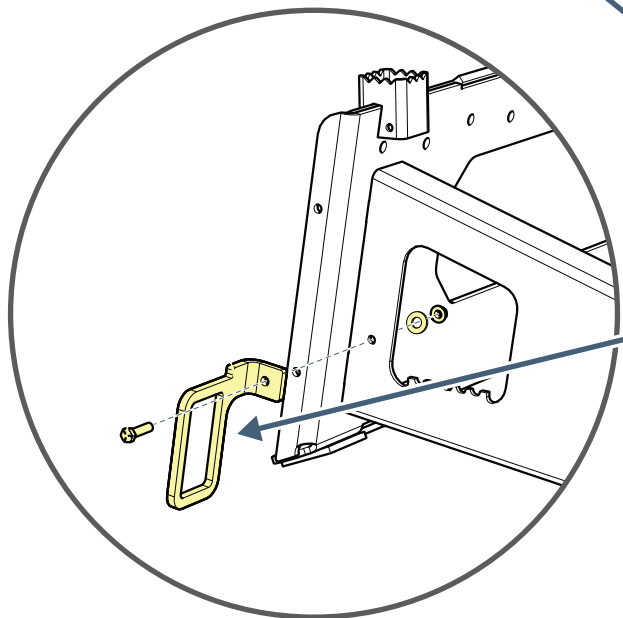

PLASTICS - GLIDE PLATE

FOR ALL MODELS

MODEL 25-60 ▼

MODEL 25-78 ▼

MODEL 25-90 ▼

PROPRIETARY AND CONFIDENTIAL

The information contained in this drawing is the sole property of MuskoX. Any reproduction in part or as a whole without the written permission of MuskoX is prohibited.

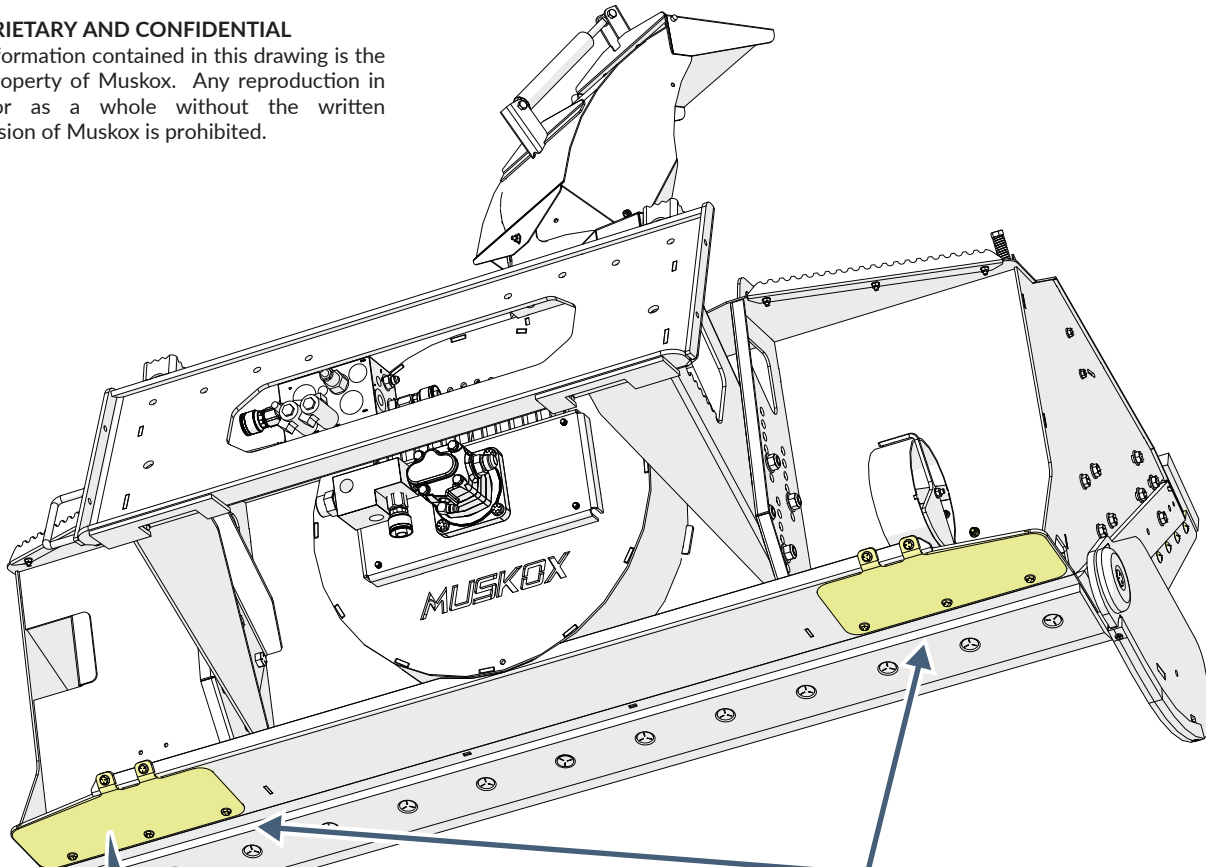

GLIDE PLATE COMBO 700-1503

INCLUDES

- BOLT,HEX-5/16"X1"-GR5 Z&C
QUANTITY: 10
- NUT,FLG NYL-5/16"-Z&C
QUANTITY: 10
- PAD,GLIDE-PLATE,RIGHT
QUANTITY: 1
- WASHER,FLAT,SAE-5/16"-Z&C
QUANTITY: 10
- PAD,GLIDE-PLATE,LEFT
QUANTITY: 1

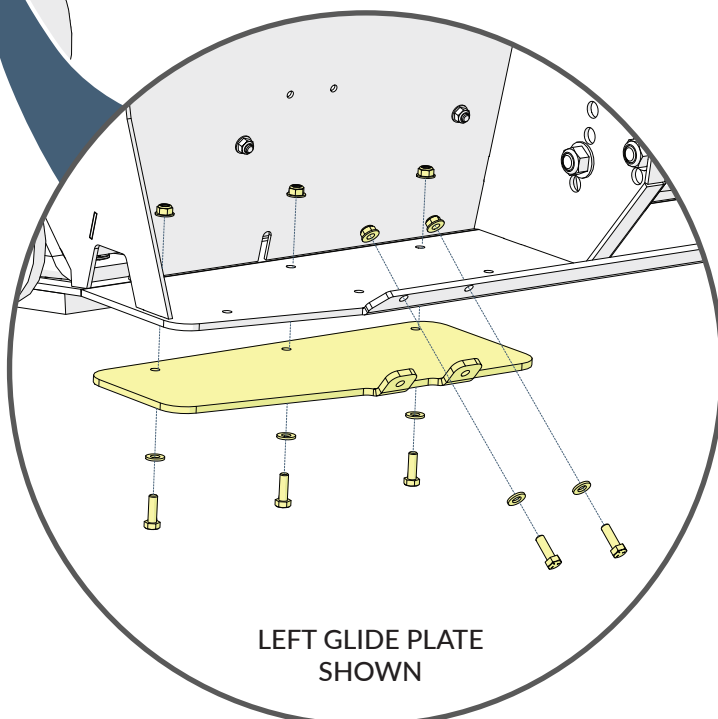

LEFT GLIDE PLATE
SHOWN



SCAN
HERE!

VIDEO TUTORIAL TO REPLACE
SKID PAD UHMW PLASTIC



PLASTIC WEAR KITS

FOR MODEL

MODEL 25-60 ▼

MODEL 25-78 ▼

MODEL 25-90 ▼

PROPRIETARY AND CONFIDENTIAL

The information contained in this drawing is the sole property of MuskoX. Any reproduction in part or as a whole without the written permission of MuskoX is prohibited.

SIDE GUIDE - COMBO 25-60/78/90 700-1513

INCLUDES

- BOLT, CARRIAGE-3/8"X1"-GR5 Z&C
QUANTITY: 10
- NUT, FLG NYL-3/8"-Z&C
QUANTITY: 10
- GUIDE, SIDE-UHMW REGRIND-BLACK
QUANTITY: 2

60" AUGER LINER'S 700-1511

INCLUDES

- GUIDE, SNOW-LWR AUGER-HMW-60"
QUANTITY: 2
- BOLT, HEX - 5/16" X 1-1/2" - Z&C
QUANTITY: 6
- WASHER, FLAT-HD - 5/16" X 1-1/4" - Z&C
QUANTITY: 6
- NUT, FLG NYL - 3/8" - Z&C
QUANTITY: 6



SCAN
HERE!



VIDEO TUTORIAL TO
REPLACE AUGER LINER UHMW



SCAN
HERE!



VIDEO TUTORIAL TO
REPLACE UHMW SIDE GUIDES

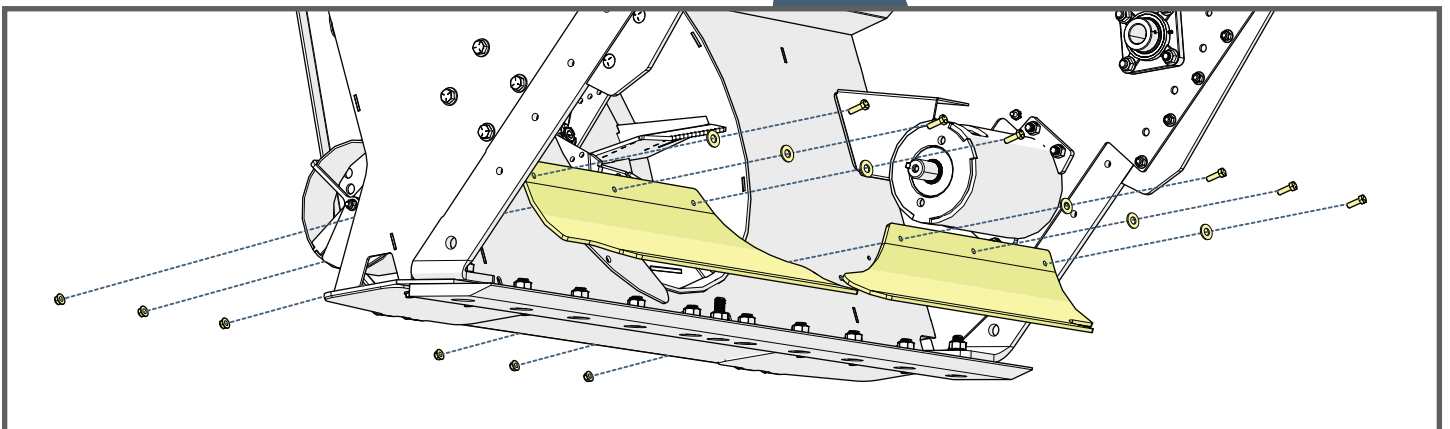

PLASTIC WEAR KITS

MODEL 25-60 ▼

FOR MODEL

MODEL 25-78 ▼

MODEL 25-90 ▼

PROPRIETARY AND CONFIDENTIAL

The information contained in this drawing is the sole property of MuskoX. Any reproduction in part or as a whole without the written permission of MuskoX is prohibited.

SIDE GUIDE - COMBO 25-60/78/90

700-1513

INCLUDES

- BOLT, CARRIAGE-3/8"X1"-GR5 Z&C
QUANTITY: 10
- NUT, FLG NYL-3/8"-Z&C
QUANTITY: 10
- GUIDE, SIDE-UHMW REGRIND-BLACK
QUANTITY: 2

78" AUGER LINER'S

700-1509

INCLUDES

- GUIDE, SNOW-LWR AUGER-HMW-78
QUANTITY: 2
- STRAP, LOWER AUGER SNOW GUIDE
QUANTITY: 2
- BOLT, HEX - 5/16" X 1-1/2" - Z&C
QUANTITY: 6
- NUT, FLG NYL - 3/8" - Z&C
QUANTITY: 6



SCAN
HERE!



SCAN
HERE!



VIDEO TUTORIAL TO
REPLACE AUGER LINER UHMW

VIDEO TUTORIAL TO
REPLACE UHMW SIDE GUIDES

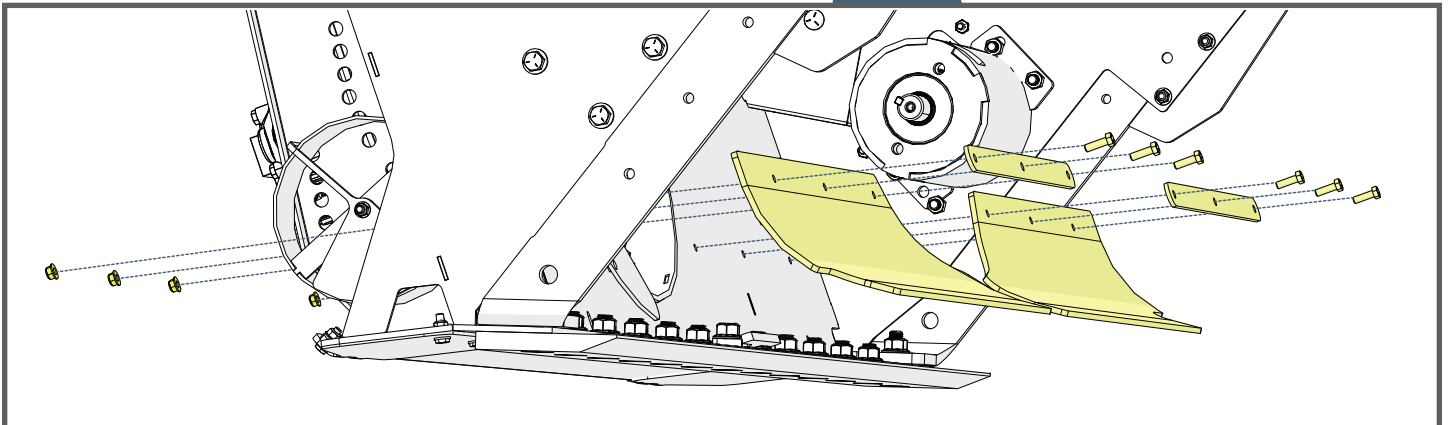

PLASTIC WEAR KITS

MODEL 25-60 ▼

MODEL 25-78 ▼

FOR MODEL
MODEL 25-90 ▼

PROPRIETARY AND CONFIDENTIAL

The information contained in this drawing is the sole property of Muskox. Any reproduction in part or as a whole without the written permission of Muskox is prohibited.

SIDE GUIDE - COMBO 25-60/78/90 700-1513

INCLUDES

- BOLT, CARRIAGE-3/8"X1"-GR5 Z&C
QUANTITY: 10
- NUT, FLG NYL-3/8"-Z&C
QUANTITY: 10
- GUIDE, SIDE-UHMW REGRIND-BLACK
QUANTITY: 2

90" AUGER LINER'S 700-1510

INCLUDES

- GUIDE, SNOW-LWR AUGER-HMW-90
QUANTITY: 2
- BOLT, HEX - 5/16" X 1-1/2" - Z&C
QUANTITY: 10
- WASHER, FLAT-HD - 5/16" X 1-1/4" - Z&C
QUANTITY: 10
- NUT, FLG NYL - 3/8" - Z&C
QUANTITY: 10



SCAN
HERE!



SCAN
HERE!



VIDEO TUTORIAL TO
REPLACE AUGER LINER UHMW

VIDEO TUTORIAL TO
REPLACE UHMW SIDE GUIDES

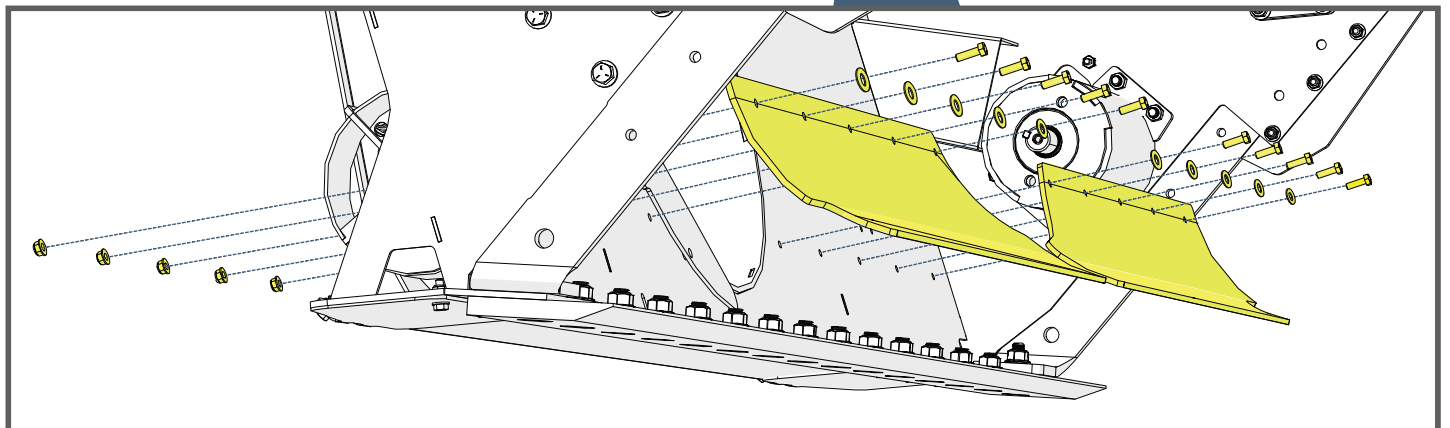

SIDE FINS

FOR ALL MODELS

MODEL 25-60 ▼

MODEL 25-78 ▼

MODEL 25-90 ▼

PROPRIETARY AND CONFIDENTIAL

The information contained in this drawing is the sole property of Muskox. Any reproduction in part or as a whole without the written permission of Muskox is prohibited.

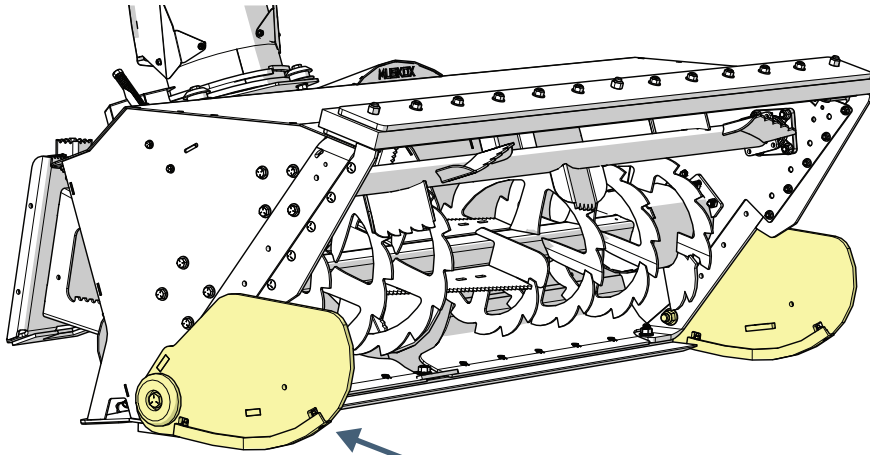

LH SIDE FIN, REPLACEMENT KIT 700-0503

INCLUDES

- PLATE, SIDE FIN-LH-WELDT
QUANTITY: 1
- SKID, FIN, EXTENDED LENGTH
QUANTITY: 1
- SCREW, MACH, CS-1/4"X1 1/2"-GR8-HEX
QUANTITY: 2
- NUT, FLG NYL-1/4"-Z&C
QUANTITY: 1
- SIDE FIN PIVOT KIT (SEE BELOW ①)
QUANTITY: 1

RH SIDE FIN, REPLACEMENT KIT 700-0502

INCLUDES

- PLATE, SIDE FIN-RH-WELDT
QUANTITY: 1
- SKID, FIN, EXTENDED LENGTH
QUANTITY: 1
- SCREW, MACH, CS-1/4"X1 1/2"-GR8-HEX
QUANTITY: 2
- NUT, FLG NYL-1/4"-Z&C
QUANTITY: 1
- SIDE FIN PIVOT KIT (SEE BELOW ①)
QUANTITY: 1



SCAN HERE!



VIDEO TUTORIAL TO REPLACE SIDE FINS

INDIVIDUAL PARTS AVAILABLE

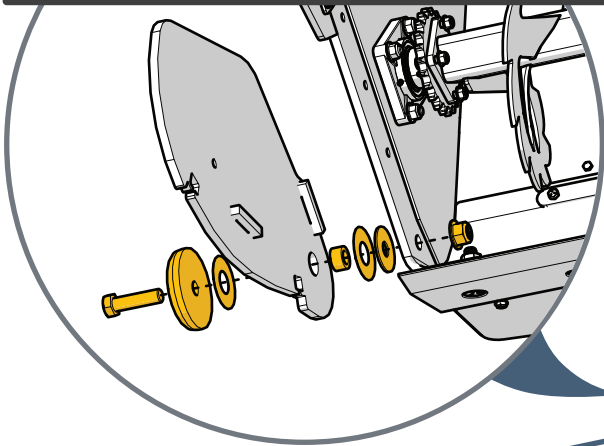

① SIDE FIN PIVOT KIT 700-0115

INCLUDES

- WASHER, FIN, MACHINED
QUANTITY: 2
- SHIM, PIVOT-SS-.0625" THICK
QUANTITY: 4
- BUSHING, FIN-SIDE
QUANTITY: 2
- NUT, FLG-TOP LOCK-3/4"-GR8-Z&C
QUANTITY: 2
- BOLT, HEX-3/4"X2 3/4"-GR8 Z&Y
QUANTITY: 2
- WASHER, PIVOT-SS-.08" THICK
QUANTITY: 2

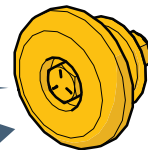

SKID, SIDE FIN-KIT-25 MODELS 700-1515

INCLUDES

- SKID, FIN, EXTENDED LENGTH
QUANTITY: 2
- SCREW, MACH, CS-1/4"X1 1/2"-GR8-HEX
QUANTITY: 6
- NUT, FLG NYL-1/4"-Z&C
QUANTITY: 6

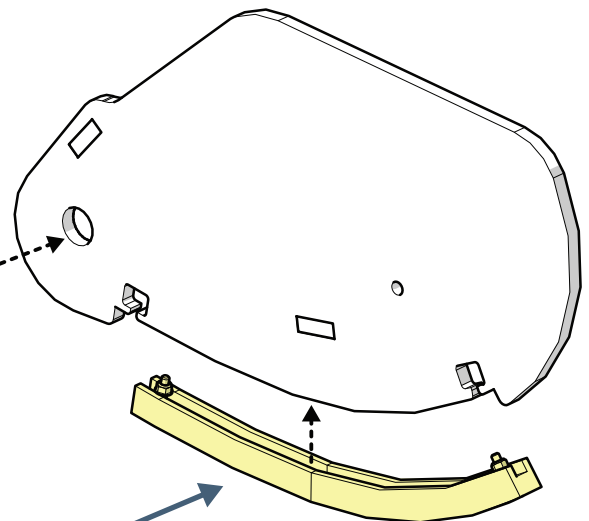

SCAN HERE!

VIDEO TUTORIAL TO REPLACE SIDE FIN UHMW PLASTIC



UPPER AUGER

FOR MODEL

MODEL 25-60 ▼

MODEL 25-78 ▼

MODEL 25-90 ▼

PROPRIETARY AND CONFIDENTIAL

The information contained in this drawing is the sole property of Muskox. Any reproduction in part or as a whole without the written permission of Muskox is prohibited.

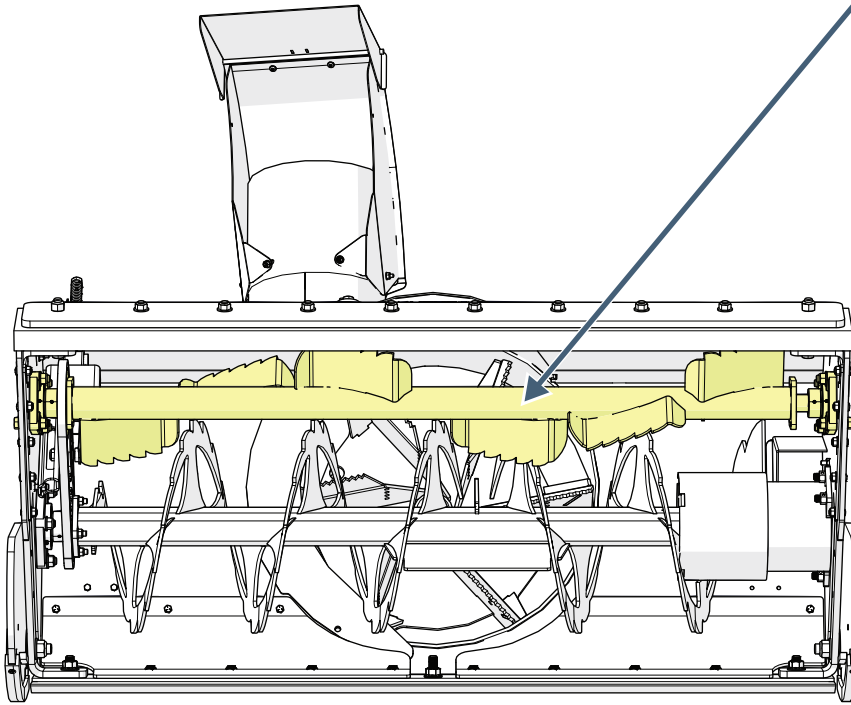

UPPER AUGER, 60"-ASSY 700-2115

INCLUDES

- NUT,FLG NYL-3/8"-Z&C
QUANTITY: 4
- BOLT,HEX-3/8"X1 1/2"-GR5 Z&C
QUANTITY: 4
- SPROCKET,#60-6024X, W/HOLE PATTERN
QUANTITY: 1
- FLANGE BEARING,1 1/4" 4 BOLT-LOCK COLLAR 206 HOUSING HCFS206-20
QUANTITY: 2
- AUGER,UPPER PADDLE,60"-WELDT
QUANTITY: 1
- BOLT,HEX-1/2"X1 3/4"-GR5 Z&C
QUANTITY: 6
- BOLT,HEX-1/2"X2 1/4"-GR5 Z&C
QUANTITY: 2
- NUT,FLG NYL-1/2"-Z&C
QUANTITY: 8
- WASHER,FLAT,SAE-1/2"-Z&C
QUANTITY: 8

INDIVIDUAL PARTS AVAILABLE

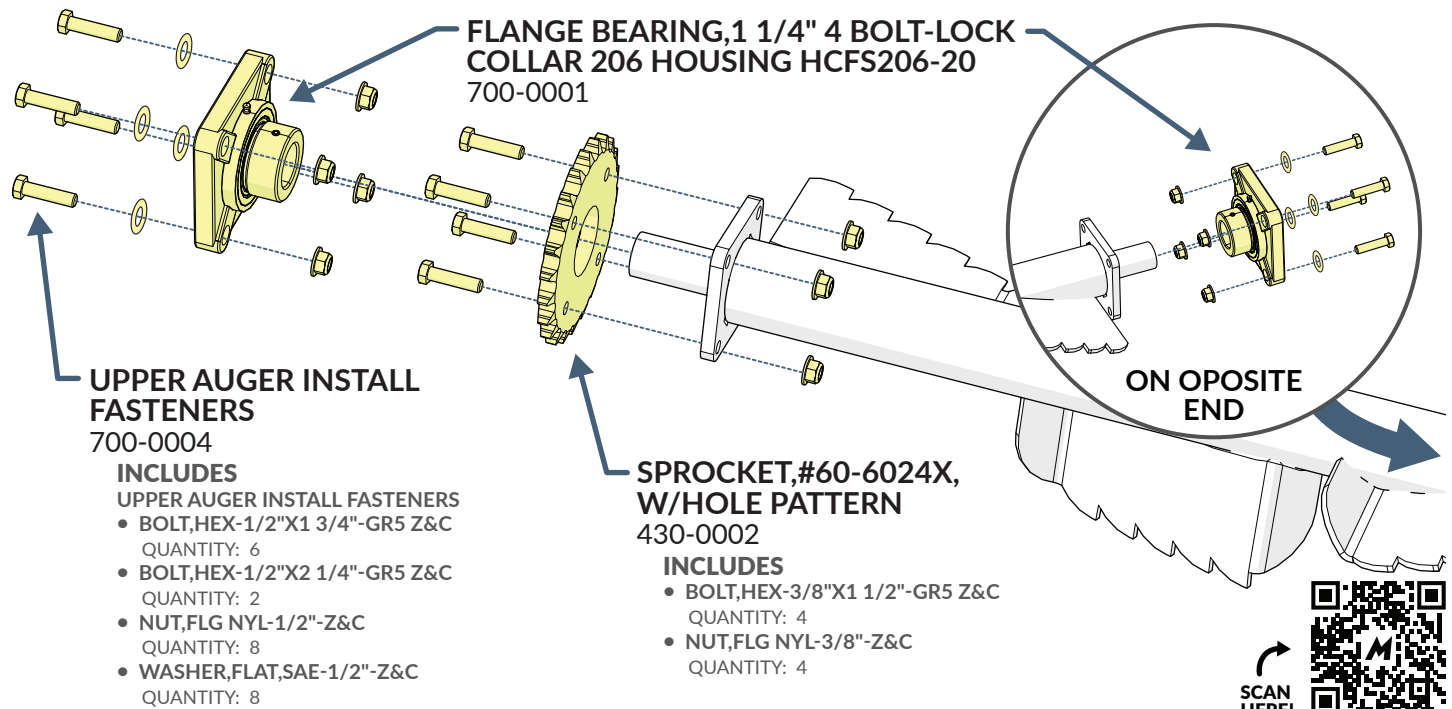

UPPER AUGER INSTALL FASTENERS 700-0004

INCLUDES

- UPPER AUGER INSTALL FASTENERS
- BOLT,HEX-1/2"X1 3/4"-GR5 Z&C
QUANTITY: 6
 - BOLT,HEX-1/2"X2 1/4"-GR5 Z&C
QUANTITY: 2
 - NUT,FLG NYL-1/2"-Z&C
QUANTITY: 8
 - WASHER,FLAT,SAE-1/2"-Z&C
QUANTITY: 8

FLANGE BEARING,1 1/4" 4 BOLT-LOCK COLLAR 206 HOUSING HCFS206-20 700-0001

SPROCKET,#60-6024X, W/HOLE PATTERN 430-0002

INCLUDES

- BOLT,HEX-3/8"X1 1/2"-GR5 Z&C
QUANTITY: 4
- NUT,FLG NYL-3/8"-Z&C
QUANTITY: 4

ON OPOSITE END

SCAN HERE!



VIDEO TUTORIAL TO
REPLACE UPPER AUGER



UPPER AUGER

MODEL 25-60 ▼

FOR MODEL

MODEL **25-78** ▼

MODEL 25-90 ▼

PROPRIETARY AND CONFIDENTIAL

The information contained in this drawing is the sole property of MuskoX. Any reproduction in part or as a whole without the written permission of MuskoX is prohibited.

UPPER AUGER, 78"-ASSY 700-2011

INCLUDES

- NUT,FLG NYL-3/8"-Z&C
QUANTITY: 4
- BOLT,HEX-3/8"X1 1/2"-GR5 Z&C
QUANTITY: 4
- SPROCKET,#60-6024X, W/HOLE PATTERN
QUANTITY: 1
- FLANGE BEARING,1 1/4" 4 BOLT-LOCK COLLAR 206 HOUSING HCFS206-20
QUANTITY: 2
- AUGER,UPR PADDLE-WELDT - 78"
QUANTITY: 1
- BOLT,HEX-1/2"X1 3/4"-GR5 Z&C
QUANTITY: 6
- BOLT,HEX-1/2"X2 1/4"-GR5 Z&C
QUANTITY: 2
- NUT,FLG NYL-1/2"-Z&C
QUANTITY: 8
- WASHER,FLAT,SAE-1/2"-Z&C
QUANTITY: 8

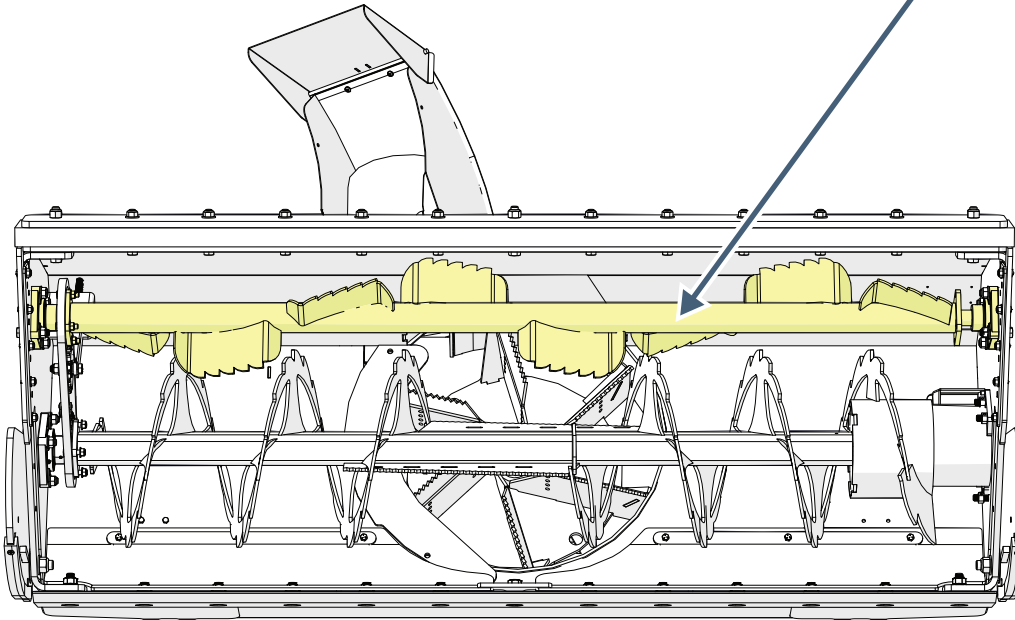

INDIVIDUAL PARTS AVAILABLE

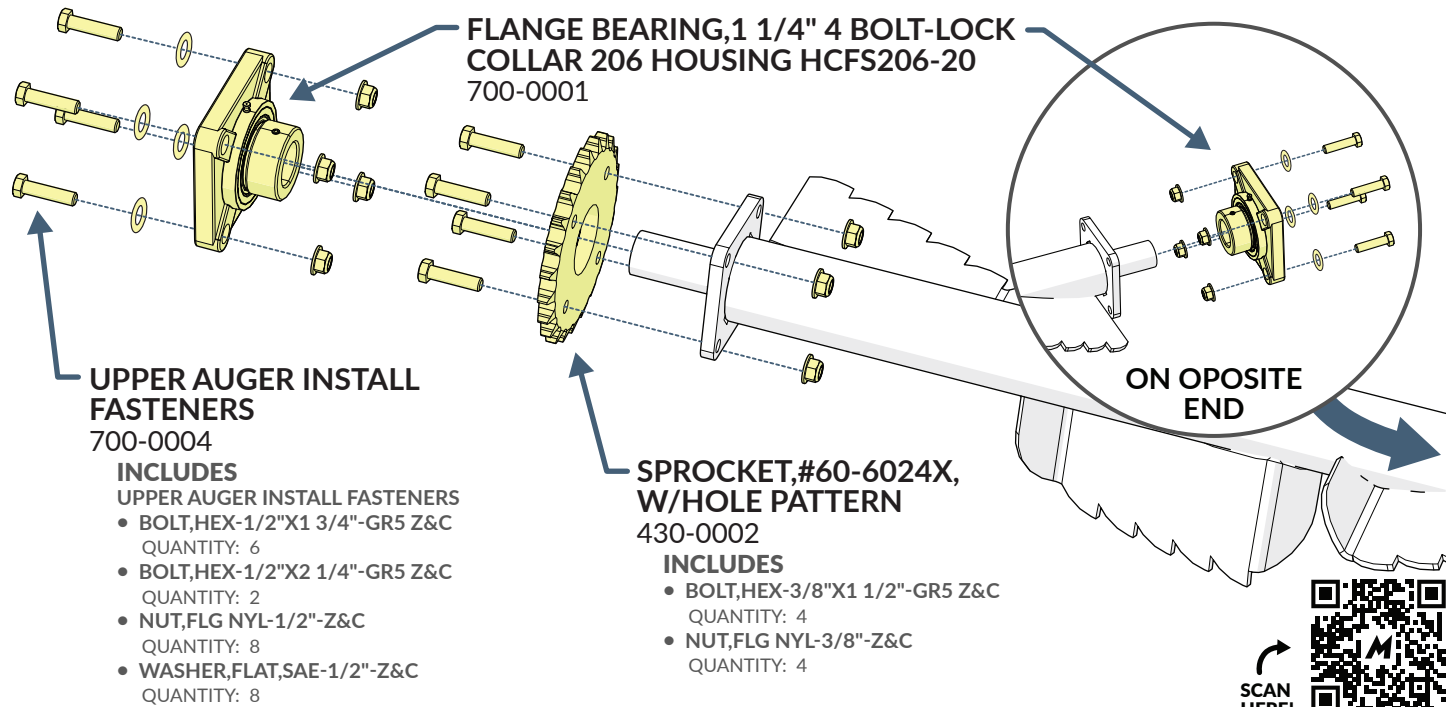

FLANGE BEARING,1 1/4" 4 BOLT-LOCK COLLAR 206 HOUSING HCFS206-20
700-0001

UPPER AUGER INSTALL FASTENERS
700-0004

- INCLUDES**
UPPER AUGER INSTALL FASTENERS
- BOLT,HEX-1/2"X1 3/4"-GR5 Z&C
QUANTITY: 6
 - BOLT,HEX-1/2"X2 1/4"-GR5 Z&C
QUANTITY: 2
 - NUT,FLG NYL-1/2"-Z&C
QUANTITY: 8
 - WASHER,FLAT,SAE-1/2"-Z&C
QUANTITY: 8

SPROCKET,#60-6024X, W/HOLE PATTERN
430-0002

- INCLUDES**
- BOLT,HEX-3/8"X1 1/2"-GR5 Z&C
QUANTITY: 4
 - NUT,FLG NYL-3/8"-Z&C
QUANTITY: 4

ON OPOSITE END

SCAN HERE!



VIDEO TUTORIAL TO REPLACE UPPER AUGER



UPPER AUGER

MODEL 25-60 ▼

MODEL 25-78 ▼

FOR MODEL
MODEL 25-90 ▼

PROPRIETARY AND CONFIDENTIAL

The information contained in this drawing is the sole property of Muskox. Any reproduction in part or as a whole without the written permission of Muskox is prohibited.

UPPER AUGER, 90"-ASSY 700-2112

INCLUDES

- NUT,FLG NYL-3/8"-Z&C
QUANTITY: 4
- BOLT,HEX-3/8"X1 1/2"-GR5 Z&C
QUANTITY: 4
- SPROCKET,#60-6024X, W/HOLE PATTERN
QUANTITY: 1
- FLANGE BEARING,1 1/4" 4 BOLT-LOCK COLLAR 206 HOUSING HCFS206-20
QUANTITY: 2
- AUGER,UPR PADDLE-WELDT - 90"
QUANTITY: 1
- BOLT,HEX-1/2"X1 3/4"-GR5 Z&C
QUANTITY: 6
- BOLT,HEX-1/2"X2 1/4"-GR5 Z&C
QUANTITY: 2
- NUT,FLG NYL-1/2"-Z&C
QUANTITY: 8
- WASHER,FLAT,SAE-1/2"-Z&C
QUANTITY: 8

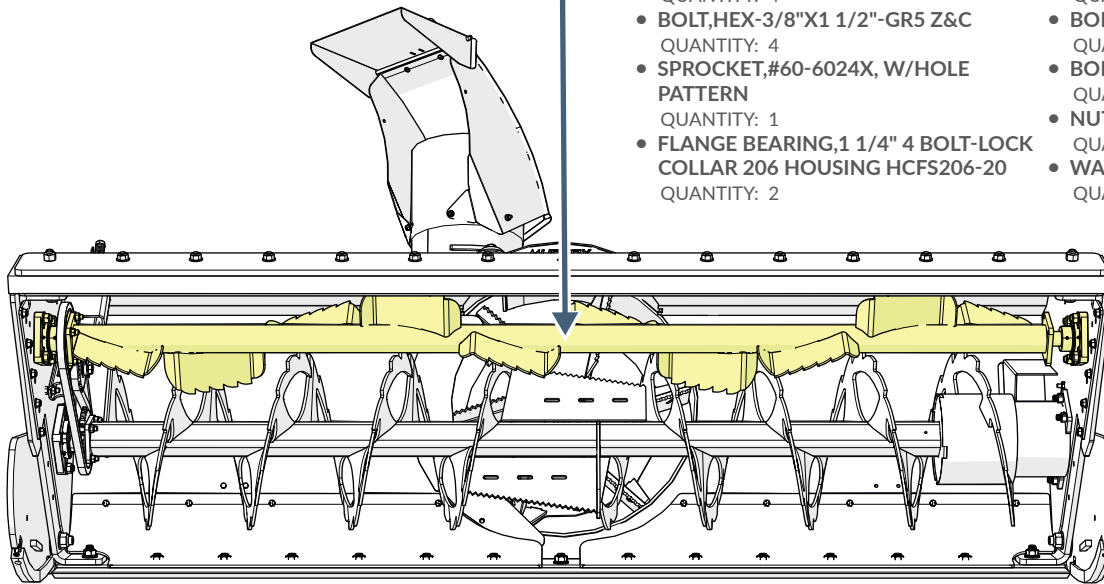

INDIVIDUAL PARTS AVAILABLE

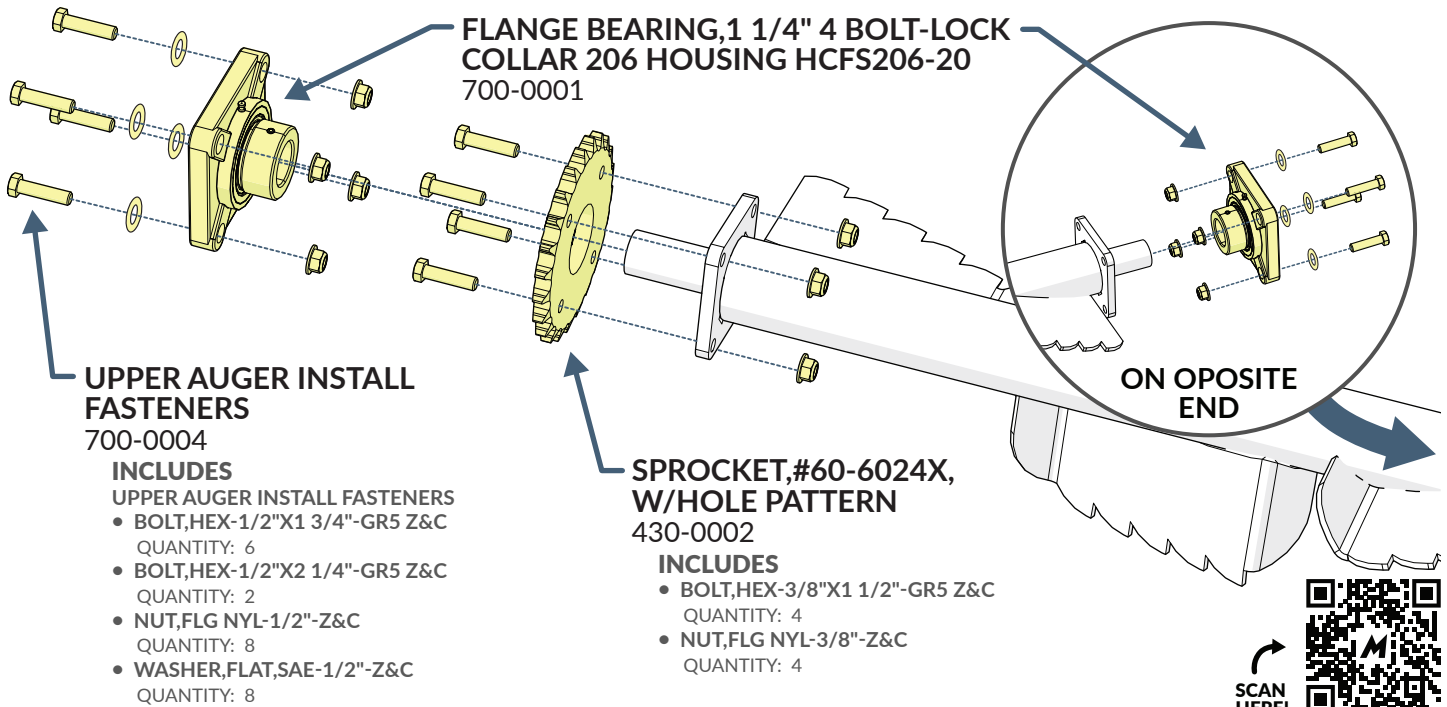

UPPER AUGER INSTALL FASTENERS 700-0004

INCLUDES

- UPPER AUGER INSTALL FASTENERS
- BOLT,HEX-1/2"X1 3/4"-GR5 Z&C
QUANTITY: 6
- BOLT,HEX-1/2"X2 1/4"-GR5 Z&C
QUANTITY: 2
- NUT,FLG NYL-1/2"-Z&C
QUANTITY: 8
- WASHER,FLAT,SAE-1/2"-Z&C
QUANTITY: 8

FLANGE BEARING,1 1/4" 4 BOLT-LOCK COLLAR 206 HOUSING HCFS206-20 700-0001

SPROCKET,#60-6024X, W/HOLE PATTERN 430-0002

INCLUDES

- BOLT,HEX-3/8"X1 1/2"-GR5 Z&C
QUANTITY: 4
- NUT,FLG NYL-3/8"-Z&C
QUANTITY: 4

ON OPOSITE END

SCAN HERE!



VIDEO TUTORIAL TO
REPLACE UPPER AUGER



BOLT TORQUE SPECIFICATIONS

GENERAL TORQUE SPECIFICATION TABLE

Use the following chart when determining bolt torque specifications when special torques are not given. Always use grade 5 or better when replacing bolts.

SAE BOLT TORQUE SPECIFICATIONS

NOTE: The following torque values are for use with extreme pressure lubricants, plating or hard washer applications. Increase torque 15 percent when using hardware that is unplated and either dry or lubricated with engine oil.

Bolt Size		SAE GRADE 5 TORQUE				SAE GRADE 8 TORQUE			
		Pounds Feet		Newton-Meters		Pounds Feet		Newton Meters	
Inches	Millimeters	UNC	UNF	UNC	UNF	UNC	UNF	UNC	UNF
1/4	6.35	8	9	11	12	10	13	14	18
5/16	7.94	14	17	19	23	20	25	27	34
3/8	9.53	30	36	41	49	38	46	52	62
7/16	11.11	46	54	62	73	60	71	81	96
1/2	12.70	68	82	92	111	94	112	127	152
9/16	14.29	94	112	127	152	136	163	184	221
5/8	15.88	128	153	174	207	187	224	254	304
3/4	19.05	230	275	312	373	323	395	438	536
7/8	22.23	340	408	461	553	510	612	691	830
1	25.40	493	592	668	803	765	918	1037	1245
1-1/8	25.58	680	748	922	1014	1088	1224	1475	1660
1-1/4	31.75	952	1054	1291	1429	1547	1700	2097	2305
1-3/8	34.93	1241	1428	1683	1936	2023	2312	2743	3135
1-1/2	38.10	1649	1870	2236	2535	2686	3026	3642	4103

BOLT HEAD IDENTIFICATION MARKS AS PER GRADE

NOTE: Manufacturing Marks Will Vary

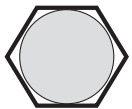

GRADE 2
No Markings



GRADE 5
3 Radial Lines



GRADE 8
6 Radial Lines

NOTE: Nylock nuts are utilized when greater resistance to vibrating loose is required, and greater operating temperatures are not a factor. In addition, like lock nuts, nylock nuts have a safety feature that if the bolt does vibrate loose, the nut will remain on the screw. Install nylock nuts to the standard torque shown above.

TORQUE SPECIFICATIONS FOR UHMW (PLASTIC) PARTS: Fasteners attached to UHMW (plastic) parts should ONLY be tightened to secure part. DO NOT OVERTIGHTEN or damage may occur to plastic part.

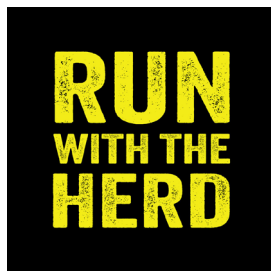

MUSKOX

601 FIRST STREET NORTH | MENTOR, MINNESOTA 56736
WWW.MUSKOXMN.COM | 218.288.1905 | SERVICE@MUSKOXMN.COM